

CL SERIES HORIZONTAL LATHE

PACKING LIST

Model :

Swing over bed :

Max. work piece length:

Produce serial NO. :



I. The main machine**Name: Horizontal Lathe** **Quantity: 1 set****Model:****Specification: (You are to identify the one which would be the best response to your needs and fill the symbol "√" in the following brackets)**

1. Max. swing over bed—500mm(20")、 630mm(25")、 660mm(26") ()
2. Max. workpiece length—750mm(30")、 1000mm(40") ()、
1500mm(60") ()、 2000mm(80") ()、 3000mm(120") ()、
4000mm(160") ()、 5000mm(200") ()
3. Saddle—available()、 unavailable()
4. Spindle nose—A8()、 A11()、 D8()、 D11()
5. Braking mode of the main transmission—brake band ()、 magnetic brake ()
6. Type of feed motion—metric ()、 inch ()、 the second kind of inch ()
7. Position of the longitudinal travel operating handwheel of the toolslide on the apron—left side ()、 right side ()
8. Three-phase power frequency—50Hz ()、 60Hz ()
9. Power voltage—220V()、 380V()、 420V()、 440V()
10. Main motor—7.5KW(10HP)()、 11KW(15HP)()、 15KW(20HP)()

II. Operating tools (in the accessory box)

- | | | | | |
|-----|-------------|-------|---------------------------------|---------|
| 1. | S77-1 | M5 | Center | 2 pc() |
| 2. | S91-1A | 10×12 | Double-ended spanner | 1 pc() |
| 3. | S91-1A | 16×17 | Double-ended spanner | 1 pc() |
| 4. | S91-1A | 18×19 | Double-ended spanner | 1 pc() |
| 5. | S91-2A | 30 | Single head wrench | 1 pc() |
| 6. | S91-7 | 5 | Socket screw hexagon wrench | 1 pc() |
| 7. | S91-7 | 6 | Socket screw hexagon wrench | 1 pc() |
| 8. | S91-7 | 8 | Socket screw hexagon wrench | 1 pc() |
| 9. | S91-7 | 10 | Socket screw hexagon wrench | 1 pc() |
| 10. | S91-7 | 14 | Socket screw hexagon wrench | 1 pc() |
| 11. | S91-7 | 17 | Socket screw hexagon wrench | 1 pc() |
| 12. | S92-3 | 17 | Square socket wrench | 1 pc() |
| 13. | S99-2 | 12.1 | Iriangulat sleeve wrench | 1 pc() |
| 14. | PM-13002/D8 | 14 | Square socket wrench (available | |

		only for spindle nose D8)	1 pc()
PM-13002/D11	17	Square socket wrench (available only for spindle nose D11)	1 pc()
15. PM-13002	150mm	Screw driver	1 pc()
16.	100mm	oil gun	1 pc()
17.PML-13011		Center sleeve	1 pc()

III. Accessories

1. Three-jaw chuck (in the accessory box)

A8 spindle nose: chuck KY315-A8 (315mm(12"), A8) 1 set()

A11 spindle nose: chuck KY400-A11(400mm(16"), A11) 1 set()

D8 spindle nose: chuck KZ315 (315mm(12")) 1 set()

chuck seat PM-091/D8B(315mm(12"), D8) 1 set()

D11 spindle nose: chuck KZ400 (400mm(16")) 1 set()

chuck seat PM-091/D11B(400mm(16"), D11) 1 set()

2. Four-jaw independent chuck, available only for lathes with saddle (in accessory box)

A8 spindle nose: chuck KH 400-A8 (400mm(16"), A8) 1 set()

D8 spindle nose: chuck KN 400 (400mm(16")) 1 set()

chuck seat PM-093/D8B(400mm)(16"), D8) 1 set()

D11 spindle nose: chuck KN 500 (500mm(20")) 1 set()

chuck seat PM-093/D11B(500mm(20"), D11) 1 set()

3. Faceplate, only for lathe with saddle (on the paperboard of packing box)

A8 Spindle nose:

Max. swing over bed Db=500mm(20")

Faceplate PM-094/50 A8(630mm(25"), A8) 1 set()

Max. swing over bed Db ≥ 630mm(25")

Faceplate PM-094/63 A8(800mm(32"), A8) 1 set()

A11 Spindle nose:

Max. swing over bed Db=500mm(20")

Faceplate PML-094/50 A11(630mm(25"), A11) 1 set()

Max. swing over bed Db ≥ 630mm(25")

Faceplate PML-094/63 A11(800mm(32"), A11) 1 set()

D8 Spindle nose:

Max. swing over bed Db=500mm(20")

-
- Faceplate PM-094/50 D8(630mm(25"）、 D8) 1 set()
 Max. swing over bed $Db \geq 630\text{mm}(25")$
 Faceplate PM-094/63 D8(800mm(32"）、 D8) 1 set()
- D11 Spindle nose:**
 Max. swing over bed $Db=500\text{mm}(20")$
 Faceplate PML-094/50 D11(630mm(25"）、 D11) 1 set()
 Max. swing over bed $Db \geq 630\text{mm}(25")$
 Faceplate PML-094/63 D11(800mm(32"）、 D11) 1 set()
4. **Steady rest: In addition to special orders, this steady rest is only available for lathes with Max. workpiece length $Lc \geq 1500\text{mm}(60")$ and Max. swing over bed $Db=500\text{mm}(20")$**
 Steady rest PM-105/50A($\phi 20\text{mm}(3/4") \sim 140\text{mm}(5\ 1/2")$ 、 $h250\text{mm}(10")$) 1 set()
 Max. swing over bed $Db=630\text{mm}(25")$
 Steady rest PM-105/63B($\phi 130\text{mm}(5\ 1/8") \sim 260\text{mm}(10\ 1/4")$ 、 $h315\text{mm}(12")$)
 1
 set()
 Max. swing over bed $Db=660\text{mm}(26")$
 Steady rest PM-105/63B($\phi 130\text{mm}(5\ 1/8") \sim 260\text{mm}(10\ 1/4")$ 、 $h330\text{mm}(13")$)
 1
 set()
5. **Follow rest ($\phi 20\text{mm}(3/4") \sim \phi 80\text{mm}(3\ 1/8")$): In addition to special orders, this follow rest is only available for lathes with Max. workpiece length $Lc \geq 1500\text{mm}(60")$**
 Max. swing over bed $Db=500\text{mm}(20")$
 Follow rest PM-102/50 ($h198\text{mm}(7\ 3/4")$) 1 set()
 Max. swing over bed $Db=630\text{mm}(25")$
 Follow rest PM-102/63 ($h263\text{mm}(10\ 3/8")$) 1 set()
 Max. swing over bed $Db=660\text{mm}(26")$
 Follow rest PM-102/66 ($h278\text{mm}(10\ 7/8")$) 1 set()
6. **Foundation bolt pack (in accessory box)**
 Each set is consisted of:
 J23-8, M20× 400 bolt 1 pc
 J12-8, M20, nut 1 pc
 J51-2, M20, washer 1 pc

Max. workpiece length $L_c \leq 1500\text{mm}(60'')$, foundation bolt

pack 6 set()

Max. workpiece length $L_c=2000\text{mm}(80'')$

$L_c=3000\text{mm}(120'')$, foundation bolt

pack 8 set()

$L_c=400\text{mm}(160'')$

$L_c=500\text{mm}(200'')$, foundation bolt

pack 10 set()

7. V-belt drive (GB1171)(at the bottom of packing box)

Main motor power 7.5KW T10 HPJ

Max. swing over bed $Db=500\text{mm}(20'')$

V-belt drive B-2235 (2235mm(88'')) 4 pc.()

Max. swing over bed $Db=630\text{mm}(25'')$

V-belt drive B-2362 (2362mm(93'')) 4 pc.()

Max. swing over bed $Db=660\text{mm}(26'')$

V-belt drive B-2388 (2388mm(94'')) 4 pc.()

Main motor power 11KW(15HP)、15KW(20HP)

Max. swing over bed $Db=500\text{mm}(20'')$

V-belt drive B-2184 (2184mm(86'')) 4 pc.()

Max. swing over bed $Db=630\text{mm}(25'')$

V-belt drive B-2311 (2311mm(91'')) 4 pc.()

Max. swing over bed $Db=660\text{mm}(26'')$

V-belt drive B-2337 (2337mm(92'')) 4 pc.()

8. Driving plate: D8 spindle nose. AB09200.(Φ 250) 1set ()

IV. Special subordinate equipments are available on request

1. Digit display unit for tool movement control

Single-coordinate

Cross raster scale and hood (on the saddle) 1 set()

Digit display unit bracket (on the saddle) 1 set()

Digit display scale (in accessory box) GSJ15 (Single-coordinate) 1 set()

Double-coordinate

Cross raster scale and hood (on the saddle) 1 set()

Vertical raster scale and hood (on the bed) 1 set()

-
- | | |
|---|-----------------|
| Digit display bracket (on the saddle) | 1 set() |
| Digit display scale (in accessory box) GSJ25 (Double-coordinates) | 1 set() |
| 2. Single-toolslide (with the machine or accessory box) | |
| Max. swing over bed Db=500mm(20") | |
| Single-toolslide PM-04/50B(L160mm(6 1/4")、 h104mm(4 3/32") | 1 set() |
| Max. swing over bed Db=630mm(25")、 660mm(26") | |
| Single-toolslide PM-04/63B(L190mm(7 1/4")、 h146mm(5 3/4") | 1 set() |
| 3. Thread chasing dial (on the saddle) | |
| Metric lathe with thread chasing dial AB-21/A | |
| (15 isometric graduations) | 1 set() |
| Inch lathe with thread chasing dial AB-21/B | |
| (16 isometric graduations) | 1 set() |
| 4. Taper copy ruler (with the machine) | |
| PM-12((300mm)(12")、 ±10°) | 1 set() |
| 5. Four-way longitudinal limited dogs | |
| (on the saddle) AB-221 (125mm(5")) | 1 set() |
| 6. Four-way transversal limited dogs | |
| (on the saddle) AB-222 (125mm(5")) | 1 set() |
| 7. Longitudinal limited dog with microadjustment | |
| (on the bed) AB-225(125mm(5")) | 1 set() |
| 8. Emergency pedal brake | |
| (between legs of machine) PM-017 | 1 set() |
| 9. Shifting device for tailstock sleeve movement | |
| PM-033 | 1 set() |
| 10. Rear chip guard (below the cover of the packing box) | |
| PML-811 | 1 set() |
| 11. Front chip hood of toolslide (on the saddle) | |
| PM-814 | 1 set() |
| 12. Rear chip hood of the saddle (on the saddle) | |
| PM-815 | 1 set() |
| V. Accessories supplied according to user's requirements | |
| 1. Three-jaw self-centering chuck with D-type | |
| transition plate (in the accessory box) | |

D8 Spindle nose: chuck KZ250 (250mm(10"))	1 set()
Chuck seat: PM-091/D8A (250mm(10"))、 D8)	1 set()
D11Spindle nose: chuck KZ315 (315mm(12"))	1 set()
Chuck seat: PML-091/D11A (315mm(12"))、 D11)	1 set()
2. Four-jaw independent chuck with D-type transition plate (in the accessory box)	
D8 Spindle nose: chuck KN320 (320mm(12"))	1 set()
Chuck seat: PM-093/D8A (320mm(12"))、 D8)	1 set()
D11 Spindle nose: chuck KN400 (400mm(16"))	1 set()
Chuck seat: PML-093/D11A (400mm(16"))、 D11)	1 set()
3. Steady rest (on the bed)	
Max. swing over bed Db=500mm(20"))	
Steady rest PM-105/50B	
(ϕ130mm(5 1/8"))~260mm(10 1/4"))、 h250mm(10"))	1 set()
Max. swing over bed Db=630mm(25"))	
Steady rest PM-105/63A	
(ϕ20mm(3/4"))~140mm(5 1/2"))、 h315mm(12"))	1 set()
Steady rest PM-105/63C	
(ϕ250mm(9 7/8"))~140mm(5 1/2"))、 h315mm(12"))	1 set()
Max. swing over bed Db=660mm(26"))	
Steady rest PM-105/66A	
(ϕ20mm(3/4"))~140mm(5 1/2"))、 h330mm(13"))	1 set()
Steady rest PM-105/66C	
(ϕ250mm(9 7/8"))~380mm(15"))、 h330mm(13"))	1 set()
4. Rolling steady rest (on the bed)	
Max. swing over bed Db=500mm(20"))	
Steady rest PM-361/50A	
(ϕ30mm(1 3/16"))~160mm(6 5/16"))、 h250mm(10"))	1 set()
Steady rest PM-361/50B	
(ϕ150mm(5 7/8"))~280mm(11"))、 h250mm(10"))	1 set()
Max. swing over bed Db=630mm(25"))	
Steady rest PM-361/63A	
(ϕ30mm(1 3/16"))~160mm(6 5/16"))、 h315mm(12"))	1 set()
Steady rest PM-361/63B	

-
- | | |
|---|-------------------|
| (ϕ150mm(5 7/8")~280mm(11")、h315mm(12")) | 1 set() |
| Steady rest PM-361/66C | |
| (ϕ270mm(10 5/8")~400mm(15 3/4")、h330mm(13")) | 1 set() |
| 5. Rapid change tool holder P1325C | |
| (6 sets of tool holder are attached) | 1 set() |
| 6. Swiveling center D415(M5) | 1 set() |
| 7. Damping washer JJD-II(ϕ120) | () set() |

VI. Technical documents (in the accessory box)

CL Series

- 1. CL SERIES HORIZONTAL LATHE OPERATION MANUAL 1copy()**
- 2. HORIZONTAL LATHE CERTIFICATE OF QUALIFICATION
1copy()**
- 3. CL SERIES HORIZONTAL LATHE PACKING LIST
1copy()**

Delivery date:

Packing date:

Packing inspector:

床身部件 BED AND BASE

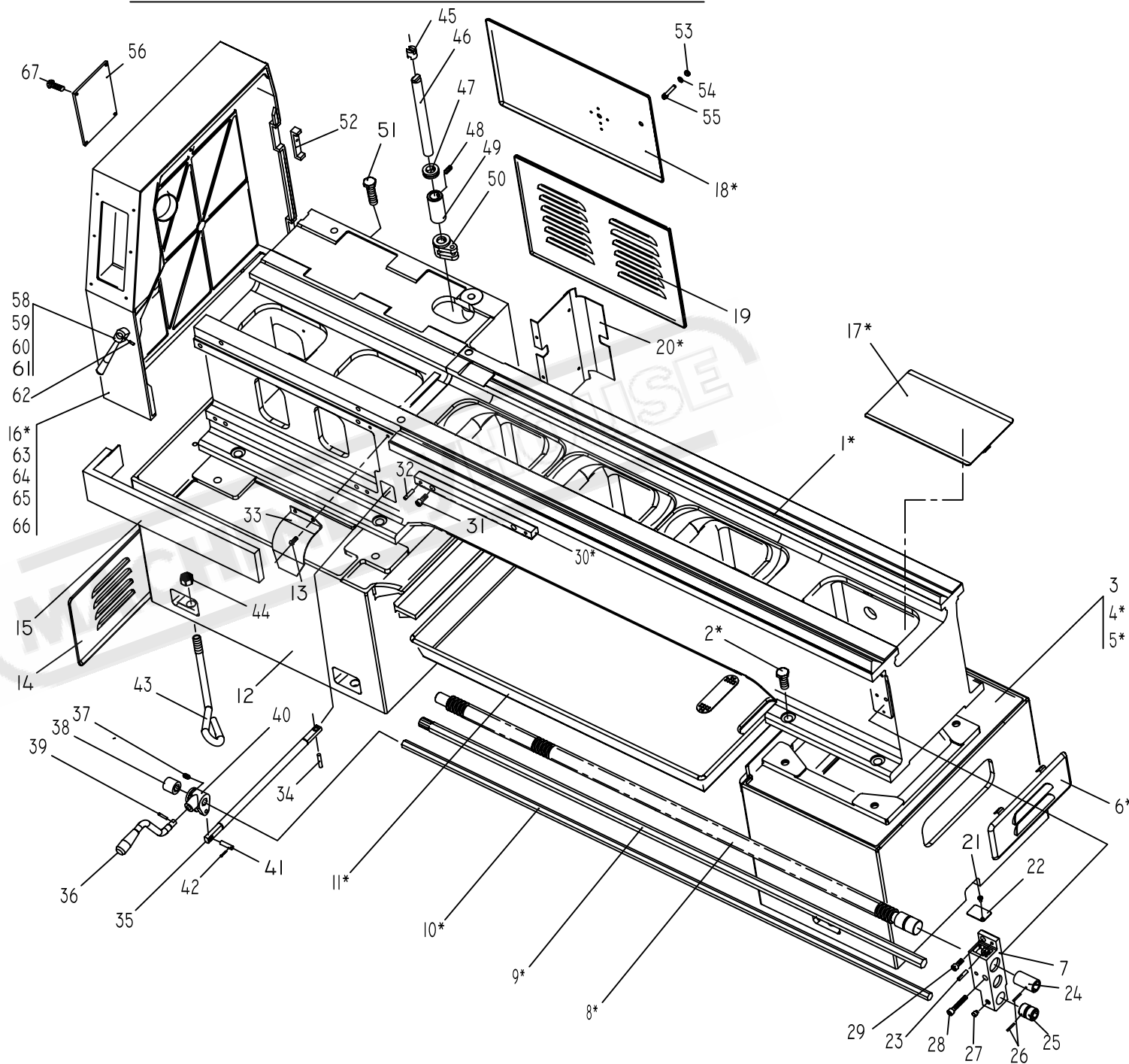

主机系统 BRAKE SYSTEM

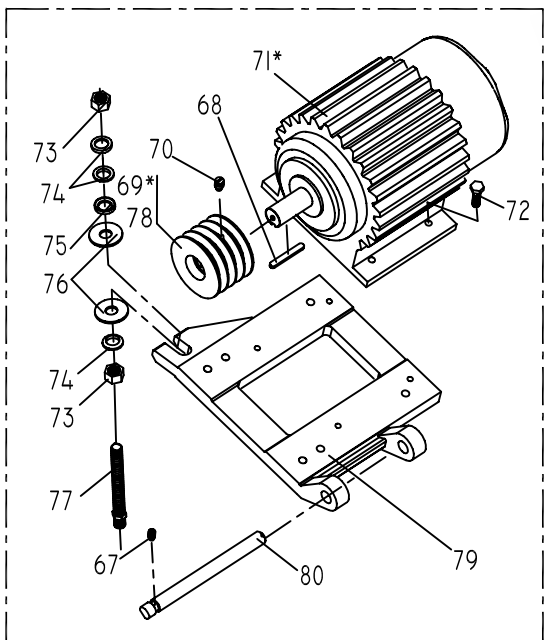

床头箱 HEAD STOCK

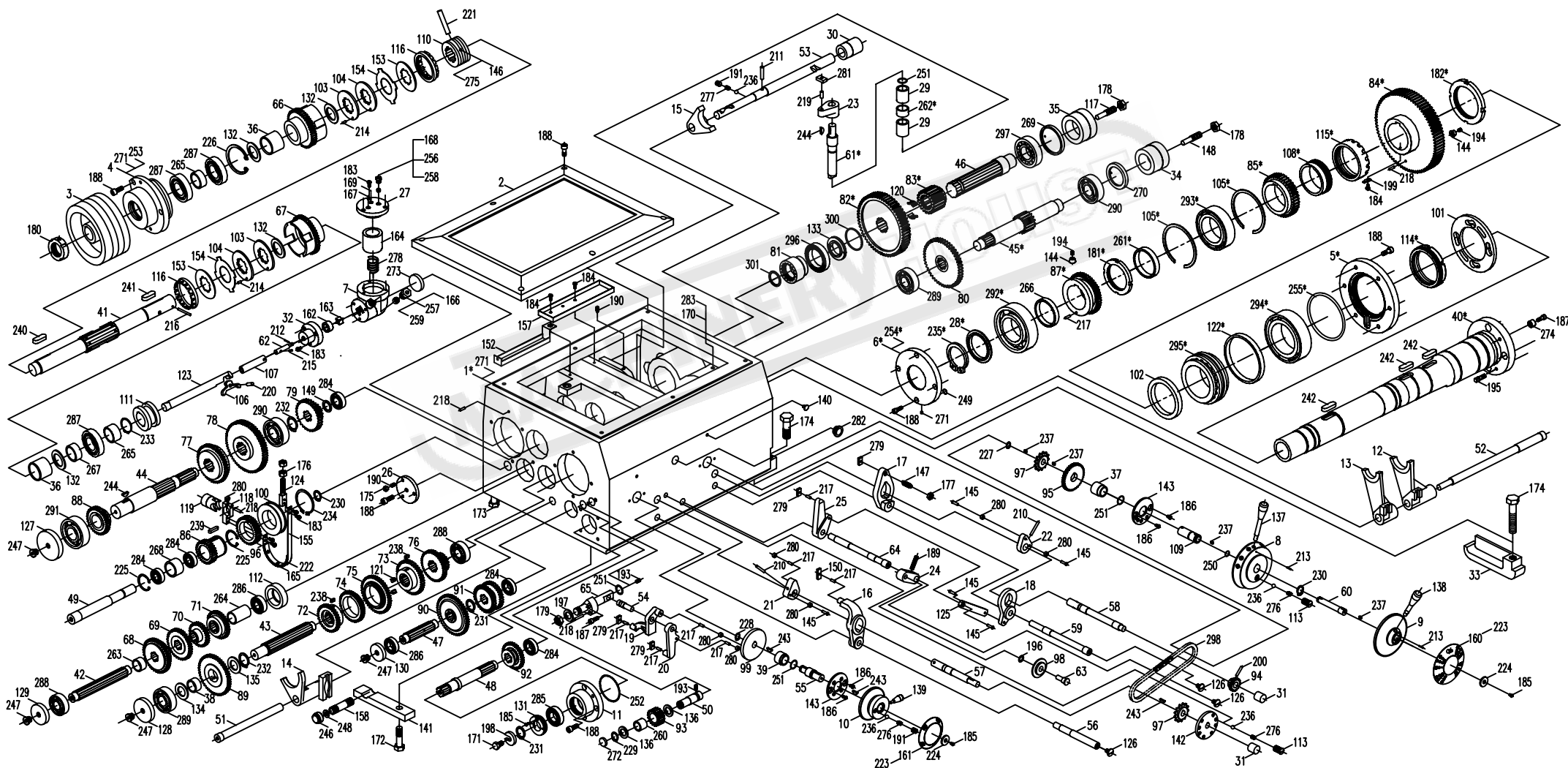

尾架 TAILSTOCK

Parts List for CL-100 (L172)

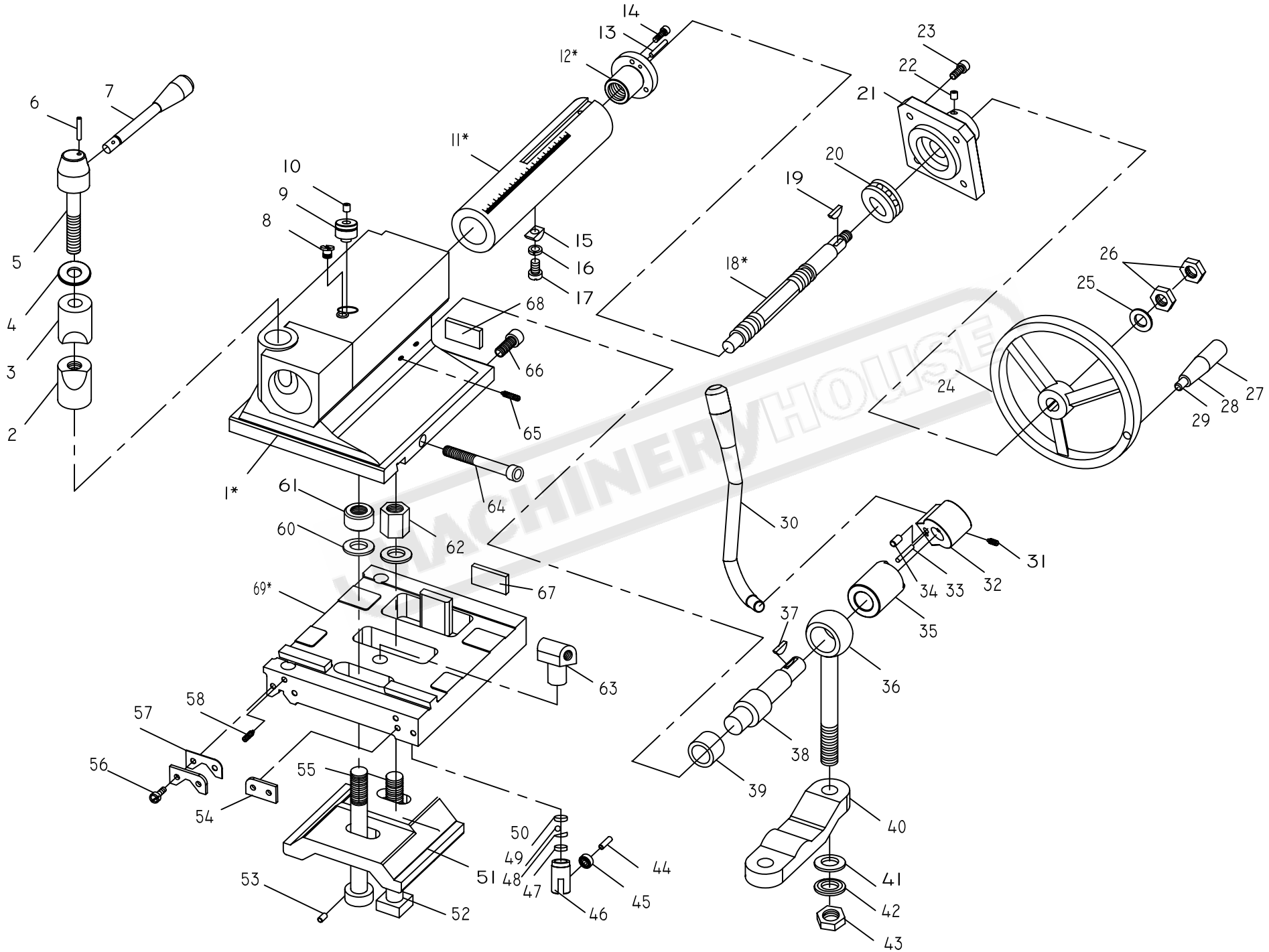

床鞍与刀架 CARRIAGE AND CROSSFEED

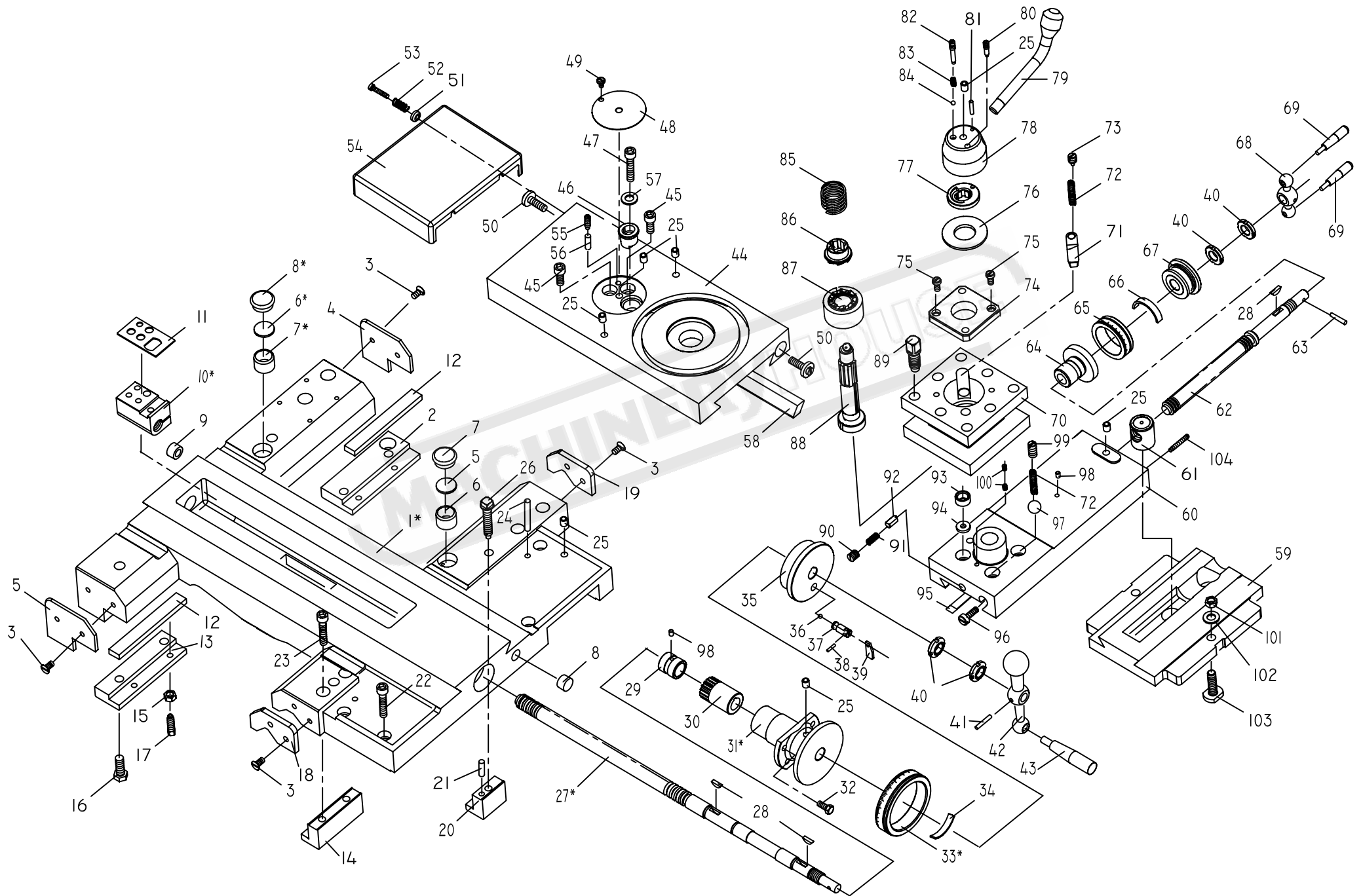

溜板箱 SLIDING BOX

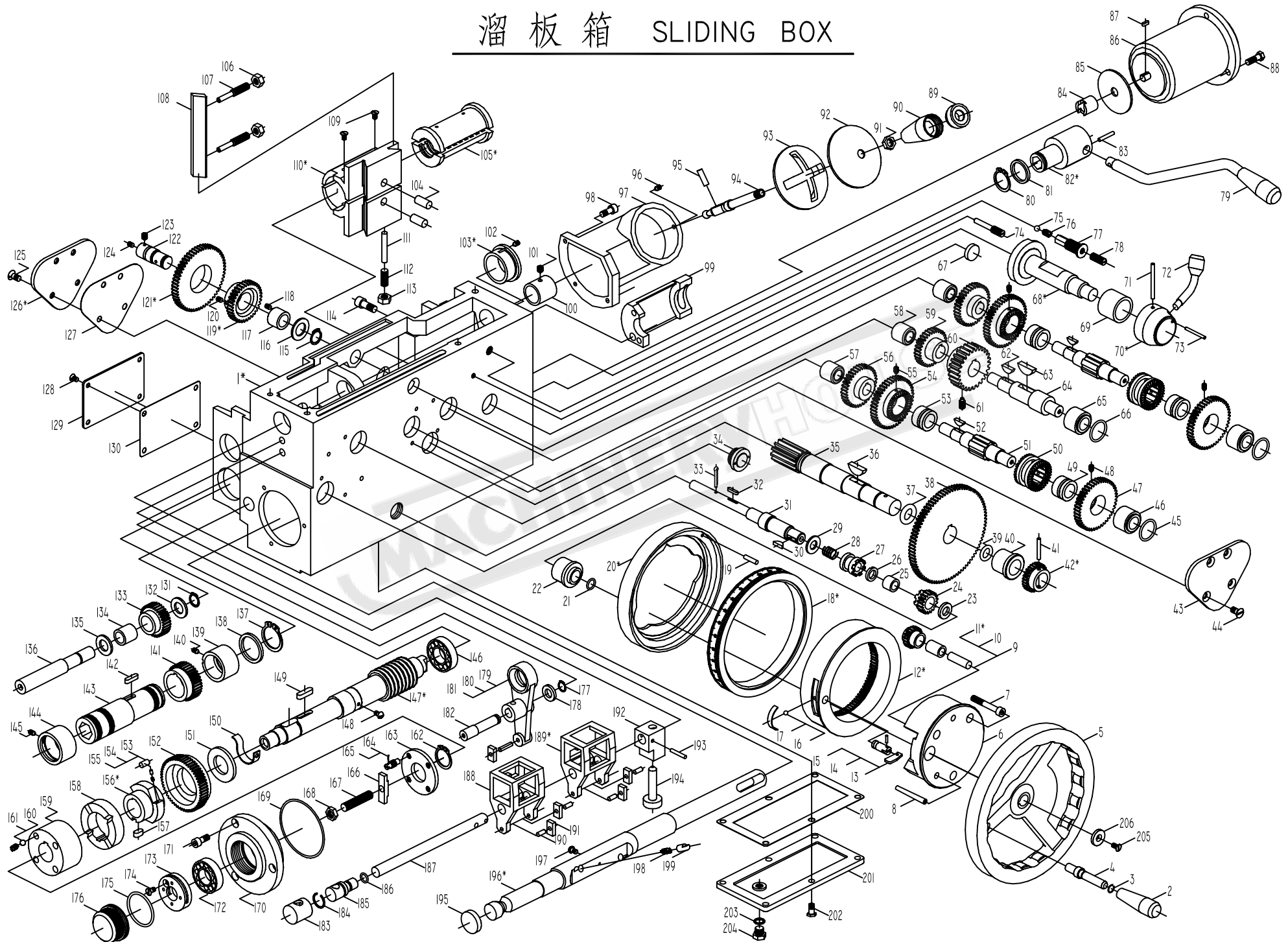

进给箱 GEAR BOX

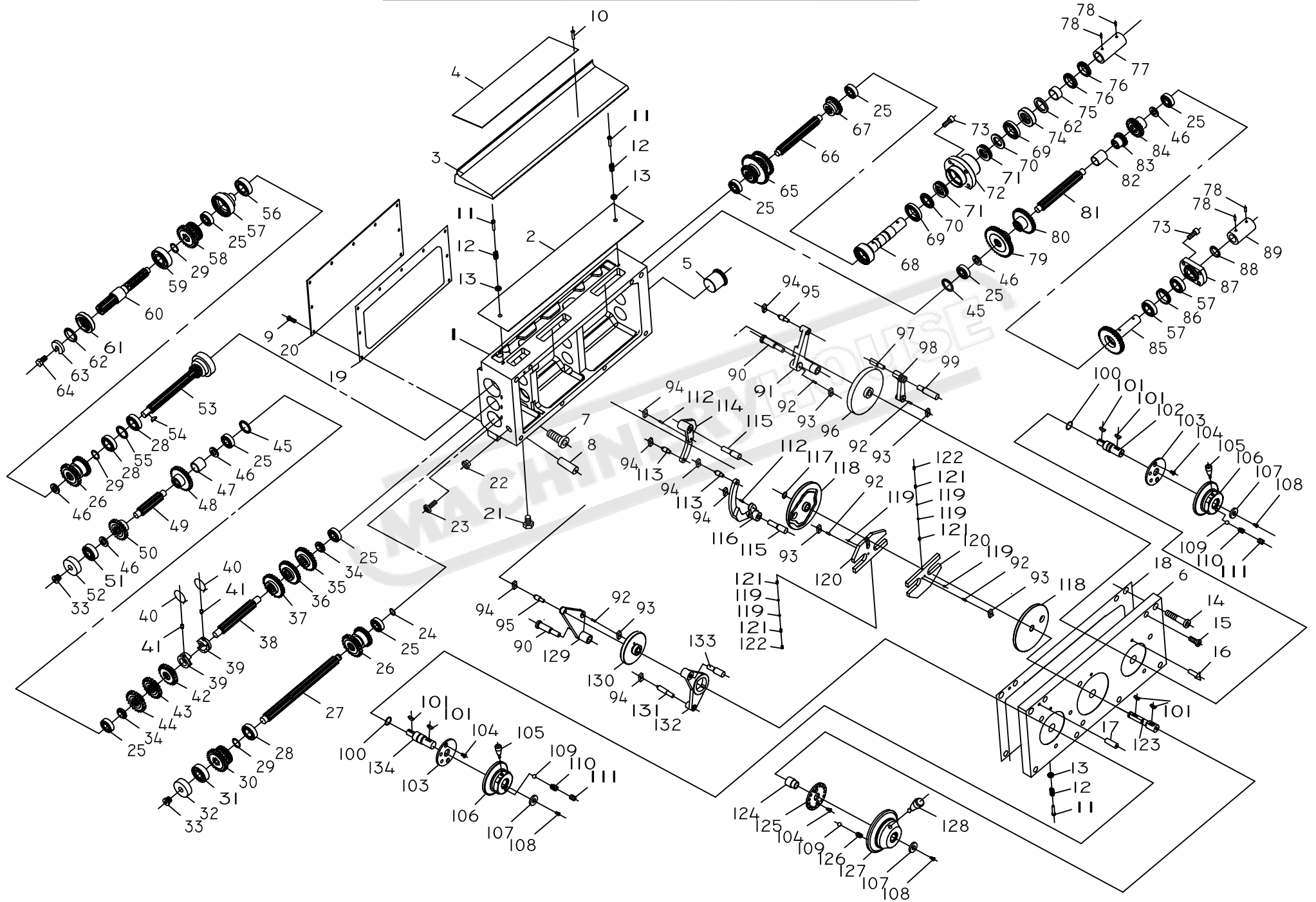

挂轮部件 CHANGE GEAR

床头箱输出轴

进给箱输入轴

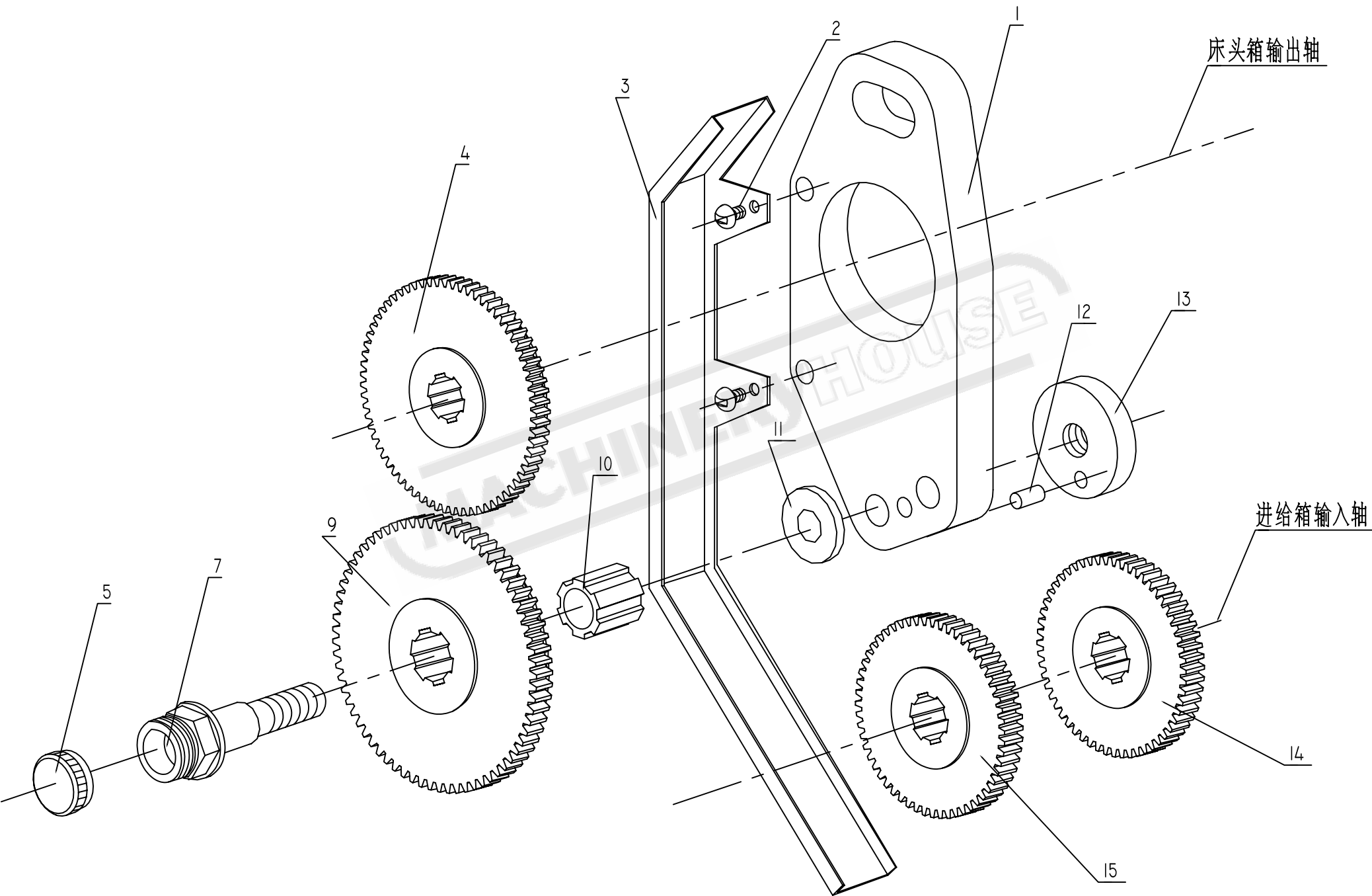

中心架 STEADY REST

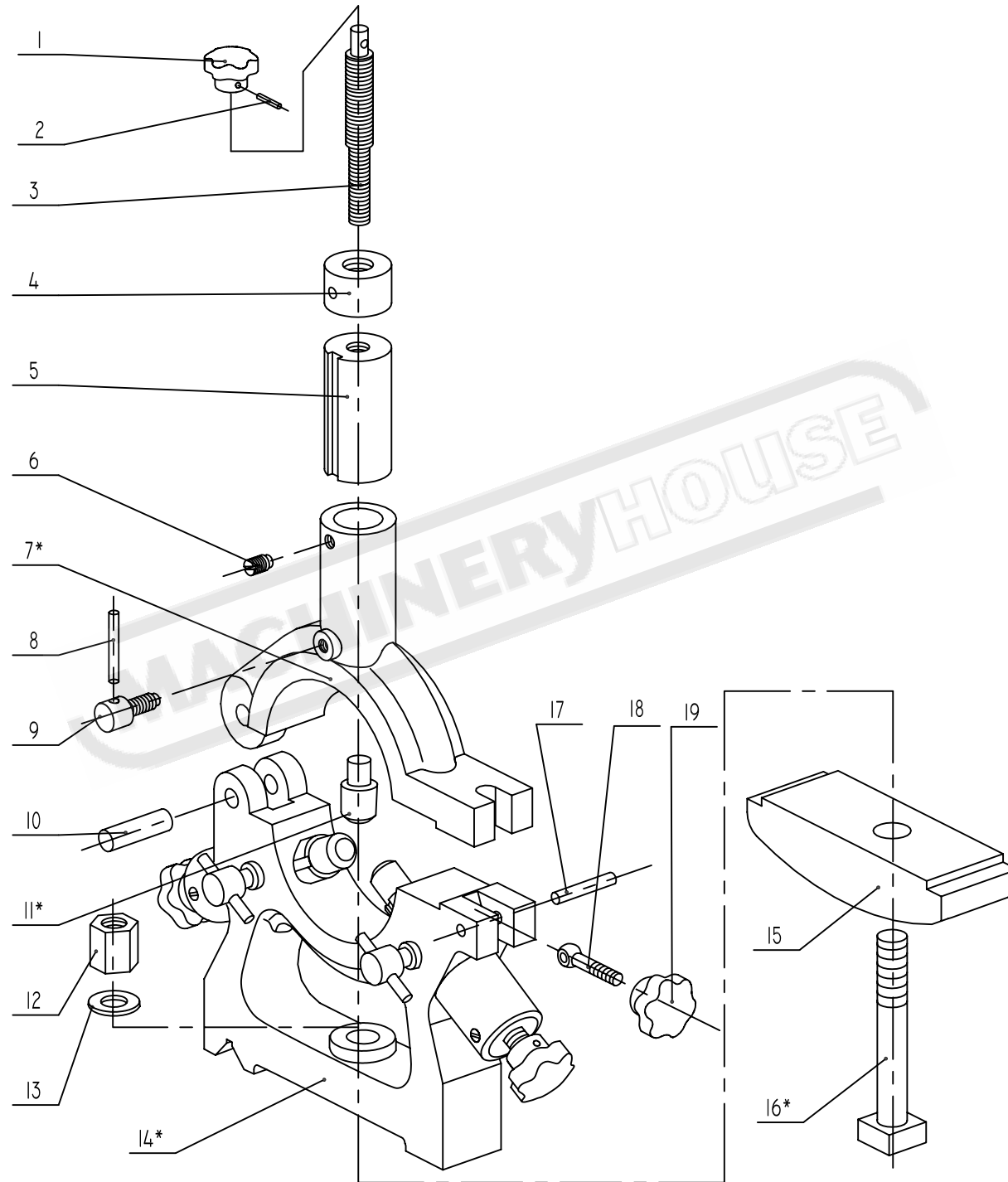

随行扶架 FOLLOW REST

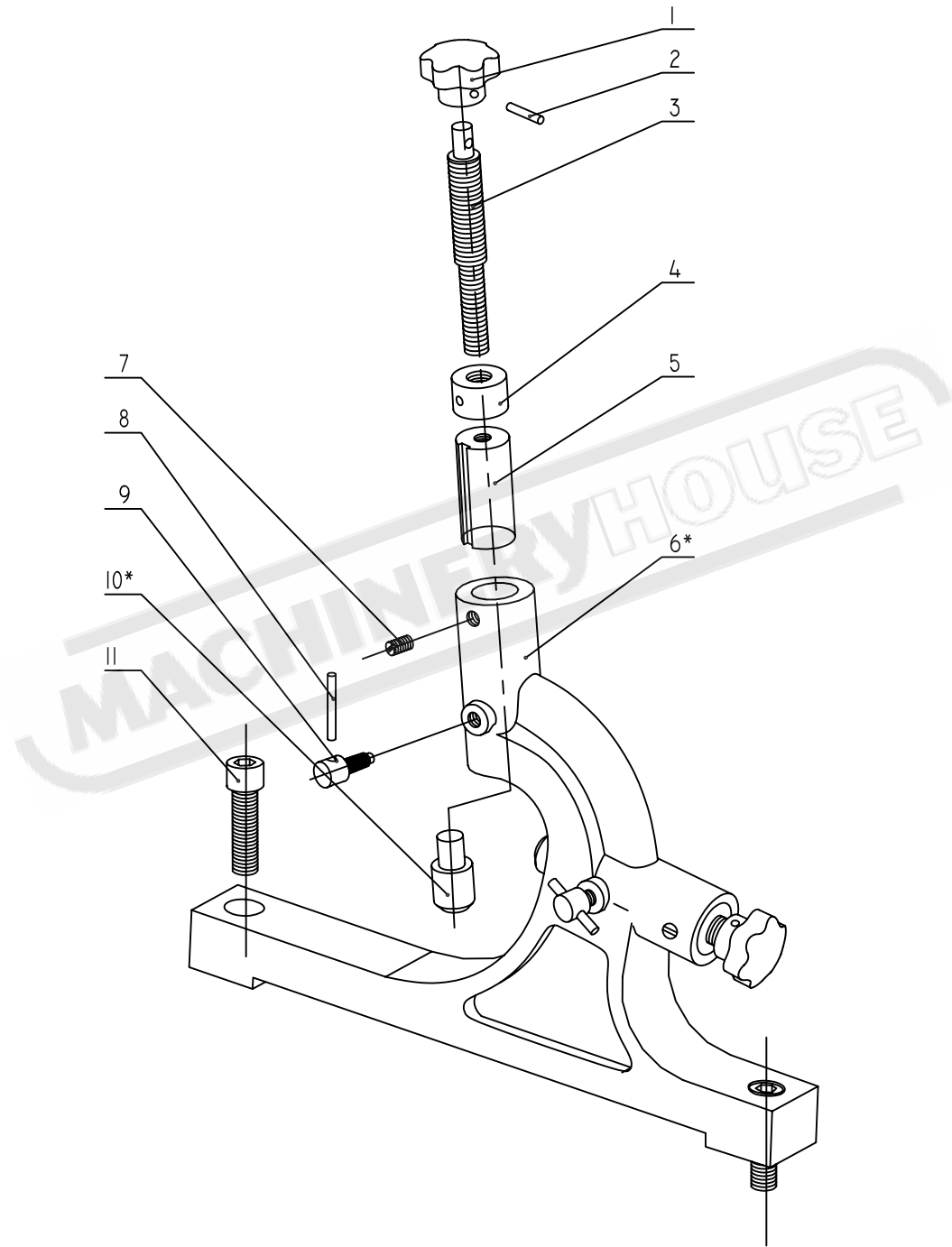



18. Element lists and disassembly draws of the main unit

Important explanations:

1. The disassembling draw of the unit is a brief figure which shows the combinatorial relationship between parts, this only for reference in maintenance and repairing. And it's not the 'warranty for the sort and quantity of the parts because the draw is not a complete assembly drawing.
2. When purchasing and referring the repair parts, be sure to give clear indication of the type (model plate) and serial number (electrical capability plate) as well as the purchase time of our products, since the machine we produced may be improved and modified.
3. Not all of the modifies are showed in the disassembling draw and given in the list .We beg your understanding . Please contact with us when meeting such problems .

The disassembly draws and corresponding lists are presented in the order of the units.

18.1 Foundation base of lathe bed 床身

Since this 《Operating Instruction》 refers eight types machine with the maximum center distance range from 750mm~5000mm ,and in order to fulfil the changes of the main motor speed cause by different power supply frequency, these situations above-mentioned are all contained in this unit .So ,the varieties about this unit are more complex .For further particulars refer to the disassembly draw of this unit and table 18-1.

18.2 Headstock 床头

The major variety of this unit is the different among type A、 C and B .The spindle thru-bore diameter is 82mm[3"] in type B ,compare with type A and C the varieties are the elements fitted on spindle and the parts concerned with head box .More details in the disassembling draw of this unit and table 18-2.

18.3 Tailstock 尾座

The variety of tailstock is dependent mainly on the major parameter (swing over bed), furthermore there has change on leadscrew and nut pitch of the tailstock in British System machine . More variation in structure when the machine is fitted with tow-speed tailstock because of the gear-shift mechanism .More details in the disassembling draw of this unit and table 18-3.

18.4 Carriage and cross slide 刀架

The variety of carriage and cross slide is dependent mainly upon the major parameter



(swing over bed), furthermore, there has changes on longitudinal leadscrew and nut, transversal leadscrew and the pitch of corresponding nut. More variation in structure when the machine is fitted taper ruler. More details in the disassembly draw of this unit and table 18-4.

18.5 Apron 溜板箱

The apron has more varieties, there has different about left-handwheel and right-handwheel besides inch size machine. When the maximum workpiece length is exceeding 1500mm, the apron is then fitted with an assistant supporting sleeve on the leadscrew. More details in the disassembly draw of this unit and table 18-5.

18.6 Feed box 进给箱

The feed box has less varieties, the major change is related to the system of metric and inch. More details in the disassembly draw and table 18-6.

18.7 Transposing gear 变速机构

Although this unit is a small one, there has more varieties about it. More details in the disassembling draw and table 18-7.

18.8 Steady rest and follow rest

The variety about this unit is related to the major parameter (swing over bed). Machine type C is provided the special steady rest and follow rest fitting this type. Consultations in the disassembly draw and table 18-8 and 18-9.



Table 18-1 Lathe bed 床身部件

Serial No.	Name	Qty.	Part No.	Remarks
1*	Lathe bed 床身	1	PM-01001/750 PM-01001/750 G	Model A and B, 750mm[30"]
			PM-01001/1000 PM-01001/1000G	Model A and B, 1000mm[40"]
			PM-01001/1500 PM-01001/1500G	Model A and B, 1500mm[60"]
			PM-01001/2000 PM-01001/2000G	Model A and B 2000mm[80"]
			AC01001/2500 A2C01001/2500	Model C, 2500 mm[100"]
			AC01001/3000 A2C01001/3000	Model C, 3000 mm[120"]
			AC01001/4000 A2C01001/4000	Model C, 4000 mm[160"]
			AC01001/5000 A2C01001/5000	Model C, 5000 mm[200"]
2*	Screw 螺钉	6	M20x50 J21-1	Range from 750mm[30"]~ 1500mm[60"]
		10		Range from 2000mm[80"]~ 3000mm[120"]
		14		Range from 4000mm[160"]~ 5000mm[200"]
3*	Hind leg 后床脚	1	PM-01003	Range from 750mm[30"]~ 2000mm[80"]
		1	AC-01003	Range from 2500mm[100"]~ 5000mm[200"]
4*	Middle leg -1 中床脚-1	1	PM-01006	Range from 750mm[30"]~ 2000mm[80"]
			AC-01006-1	Range from 2500mm[100"]~ 5000mm[200"]
5*	Middle leg-2 中床脚-2	1	AC-01006-2	Range from 4000mm[160"],5000mm[200"]
6*	cap 盖	1	A-01055	Range from 750mm[30"]~ 1500mm[60"]
		2		Range from 2000mm[80"]~ 3000mm[120"]
		3		Range from 4000mm[160"], 5000mm[200"]



Continuous table 1

7	支架 Bearing bracket 托座	1	A-01005	Range from 750mm[30"]~ 2000mm[80"]
			AC-01005	Range from 2500mm[100"]~ 5000mm[200"]
8*	leadscrew 丝杆 大丝杆 导杆 螺母	1	A-01021/750	Metric 750mm[30"]
			A-01021/750-R	Metric 750mm[30"] right-handwheel
			A-01021/1000	Model A、metric model B 1000mm[40"]
			A-01021/1000-R	Metric 1000mm[40"] right-handwheel
			A-01021/1500	Metric 1500mm[60"]
			A-01021/1500-R	Metric 1500mm[60"] right-handwheel
			A-01021/2000	Metric 2000mm[80"]
			A-01021/2000-R	Metric 2000mm[80"] right-handwheel
		1	AB-01021/750	Inch 750mm[30"]
			AB-01021/750R	Inch 750mm[30"] right-handwheel
			AB-01021/1000	Inch 1000mm[40"]
			AB-01021/100R	Inch 1000mm[40"] right-handwheel
			AB-01021/1500	Inch 1500mm[60"]
			AB-01021/1500R	Inch 1500mm[60"] right-handwheel
			AB-01021/2000	Inch 2000mm[80"]
			AB-01021/2000R	Inch 2000mm[80"] right-handwheel
		1	AC-01021/2.5m	Model C2500mm [100"]
			AC-01021/2.5mR	Model C 2500mm [100"] right-handwheel
			AC-01021/3000	Model C3000mm [120"]
			AC-01021/3M B	Model C 3000mm [120"] right-handwheel
			AC-01021/4000	Model C 4000mm [160"]
AC-01021/3M B	Model C 4000mm [160"] right-handwheel			
AC-01021/5000	Model C 5000mm [200"]			
9*	Feed rod 光杆	1	A-01022/750	Model A 、 B 750mm[30"]
			A-01022/1000	Model A 、 B 1000mm[40"]



Continuous table 2

			A-01022/1500	Model A 、 B 1500mm[60"]
			A-01022/2000	Model A 、 B 2000mm[80"]
			AC-01022/25m	Model C 2500mm [100"]
			AC-01022/3000	Model C 3000mm [120"]
			AC-01022/4000	Model C 4000mm [160"]
			AC-01022/5000	Model C 5000mm [200"]
10*	Operating lever 操纵杆	1	A-01023/750	Model A 、 B 750mm[30"]
			A-01023/1000	Model A 、 B 1000mm[40"]
			A-01023/1500	Model A 、 B 1500mm[60"]
			A-01023/2000	Model A 、 B 2000mm[80"]
			AC-01023/25m	Model C 2500mm [100"]
			AC-01023/3000	Model C 3000mm [120"]
			AC-01023/4000	Model C 4000mm [160"]
			AC-01023/5000	Model C 5000mm [200"]
11*	●oil pan 油盘	1	A-01051/750,2000-1	Model A 、 B 750mm[30"]
			A-01051/1000	Model A 、 B 1000mm[40"]
			A-01051/1500	Model A 、 B 1500mm[60"]
		1	A-01051/750,2000-1	Model A 、 B 2000mm[80"]
		1	A-01051/2000	
		1	AC-01051/2.5mm-1	Model C 2500mm [100"]
		1	AC-01051/2.5mm-2	
		1	AC-01051/3mm-1	Model C 3000mm [120"]
		1	AC-01051/3mm-2	
		1	AC-01051/4mm-1	Model C 4000mm [160"]
		2	AC-01051/4mm-2	
		1	AC-01051/5mm-1	Model C 5000mm [200"]
		2	AC-01051/5mm-2	
12	Front leg 前脚	1	PM-01002/A	
13	Screw 螺钉	2	M8×12	
14	Cap 盖	1	A-01054	
15	Cap piece 罩盖	1	A-01073	
16*	Cover 罩	1	A-01071B or A-01072A	Swing over bed 400mm[16"]
			A ₁ -01071B or A ₁ -01072A	Swing over bed 500mm[20"]



Continuous table 3

17*	Cap 盖	1	A-01056/750, 1000	750mm[30"], 1000mm[40"]		
			A-01056/1500, 2000	1500mm[60"], 2000mm[80"]		
		AC-01056	2	Model C 2500mm [100"]		
			2	Model C 3000mm [120"]		
			3	Model C 4000mm [160"]		
3	Model C 5000mm [200"]					
18*	Cap 盖	1	AB-01053	Without electrical obstructing		
			AB-01053	With electrical obstructing		
19	Cap 隔板	1	A-01052B			
20*	Baffle 隔板	1	A-01076A	Without electrical obstructing		
	Cap 盖			With electrical obstructing		
21	Screw 螺钉	1	M6x10 J21-4			
22	Cap 盖	1	A-01057			
23	Pin 销	2	8x35 J41-2			
24	Bush 套	1	A-01012			
25	Bush 套	1	A-01013			
26	Pin 销	2	4x30 J44-1			
27	Screw 螺钉	1	M8x10 J22-1			
28	Socket head cap 内六角螺钉	1	M10x70 J21-9			
29	Socket head screw	1	M10x25 J21-9			
30*	Teeth bar 齿条	2	A-01024	750mm[30"]		
		1	A-01025			
		3	A-01024			
		4	A-01024	1500mm[60"]		
		6	A-01024	2000mm[80"]		
		6	A-01024	Model C 2500mm [100"]		
		8		Model C 3000mm [120"]		
		11		Model C 4000mm [160"]		
		13		Model C 5000mm [200"]		
		1		A-01025	Model C 4000mm [160"]	
				Model C 5000mm [200"]		
		31*	Socket screw 内六角螺钉	6	M10x35 J21-9	Model A 、 B 750mm[30"]
				8		Model A 、 B 1000mm[40"]
12	Model A 、 B 1500mm[60"]					
10	Model A 、 B 2000mm[80"]					
12	Model C 2500mm [100"]					
16	Model C 3000mm [120"]					
20	Model C 4000mm [160"]					
	Model C 5000mm [200"]					



Continuous table 4

32*	Pin 销	6	8x45 J41-2	Model A 、 B 750mm[30"]
		8		Model A 、 B 1000mm[40"]
		12		Model A 、 B 1500mm[60"]
		10		Model A 、 B 2000mm[80"]
		12		Model C 2500mm [100"]
		16		Model C 3000mm [120"]
		20		Model C 4000mm [160"]
				Model C 5000mm [200"]
33	Cap 盖	1	A-01074	
34	Screwed pin	1	10x50 J41-3	
35	Pull rod	1	A-01033	
36	Handle	1	A-01031	
37	Holding screw	1	M8x16 J22-4	
38	Bush	1	A-01014	
39	Pin	1	5x30 J41-1	
40	Handle seating	1	A-01009	
41	Pin	1	10x50	
42	Split pin 开销	2	3x16 J44-9	
43	Foundation adjusting bolt 地脚螺栓	6	M20x50 J21-1	Range from 750mm[30"]~ 1500mm[60"]
		10		Range from 2000mm[80"]~ 3000mm[120"]
		14		Range from 4000mm[160"], 5000mm[200"]
44	Nut 螺母	6	M20 J12-8	Range from 750mm[30"]~ 1500mm[60"]
		10		Range from 2000mm[80"]~ 3000mm[120"]
		14		Range from 4000mm[160"], 5000mm[200"]
45	Adapter 接头	1	A-01036	
46	Shaft 轴	1	A-01032	
47	Locking sleeve	1	25 J65-1	
48	Holding screw	1	M8x10 J22-4	
49	Bush	1	A-01011	
50	Rod end yoke	1	A-01008	
51	Bolt 螺栓	2	M20x80 J21-1	
52	Gemel 链条	4	Q72-2-31	
53	Nut 螺母	2	M8 J11-1	
54	Clout 扣圈	2	8 J51-1	
55	Nail 支钉	2	A-01037	



Continuous table 5

56	Data plate 数据牌	1	A-01091	
57	Rivet 铆钉	4	2x4 J83-1	
58	Handle 手柄	1	B-(Cr)L10x80 Z14-1	
59	Hook 钩	1	A-01015	
60	Lock 锁	1	A-01016	
61	Pin 销	1	10x45 J41-1	
62	Pin 销	1	3x20 J41-1	
63	Socket head cap screw 内六角螺钉	2	M6x35 J21-9	
64	Pin 销	1	6x25 J44-1	
65	Pin 销	1	4x25 J44-1	
66	Pin 销	2	6x70 J44-1	
67	Holding screw 固定螺钉	1	M12x20 J22-10	
68	Key 键	1	8x56 J31-1A	
69*	Belt pulley 皮带轮	1	A-01007	Motor frequency : 50Hz
			AB-01007	Motor frequency : 60Hz
70	Holding screw	1	M12x20 J22-6	
71	Main motor 主电机	1	Y132M-4	7.5kW
			Y160M-4	11kW
			Y160L-4	15kW
72	Screw 螺钉	4	M10x35 J21-1	
73	Nut 螺母	2	M20 J11-1	
74	Washer 垫圈	3	20 J53-1	
75	Washer 垫圈	1	A-01082	
76	Big washer 大垫圈	1	20 J51-3	
77	Screw bolt 螺栓	1	A-01034	
78	V-belt 三角带	4	B-2210	Motor size: Y132M-4
			B-2184	Motor size: Y160M-4/ Y160L-4
79	Motor cabinet 电机柜	1	AB-01004	
80	Shaft 轴	1	A-01035	



Table 18-2

headstock

车头箱零件

Serial No.	Name	Unit	Part No.	Remark
1*	Box 箱体	1	A—02001 A	Model A、C Swing over bed 400[16"]
			A1-02001A	Model A、C Swing over bed 500[20"]
			AB—02001 A	Model B Swing over bed 400[16"]
			A1B-02001A	Model B Swing over bed 500[20"]
2	Top 箱盖	1	A—02002	
3	Belt pulley 皮带轮	1	A—02003	
4	Bearing seat 轴承座	1	A—02004	
5	Cap 盖	1	A—02005	Model A、C
			AB—02005	Model B
6	Cap 盖	1	A—02006	
7	Pump body 泵体	1	A—02007	
8	Handle seat 手柄座	1	A—02008	
9	Handle seat	1	A—02009	
10	Handwheel 手轮	3	A—02011	
11	Bearing seat 轴承座	1	A—02012	
12	Fork 拨叉	1	A—02013	
13	Fork	1	A—02014	
14	Fork	1	A—02015	
15	Fork	1	A—02016	
16	Lever 杠杆	1	A—02017	
17	Lever	1	A—02018	
18	Lever	1	A—02019	
19	Lever	1	A—02021	
20	Lever	1	A—02022	
21	Lever	1	A—02023	
22	Lever	1	A—02024	
23	Lever	1	A—02025	
24	Lever	1	A—02026	
25	Lever	1	A—02027	
26	Cap 盖	1	A—02028	
27	Cap	1	A—02029	
28*	Ring 环	1	A—02031	Model A、C
			AB-02031	Model B
29	Bush 套	2	A—02032	
30	Bush 套	1	A—02033	



Continuous table 1

31	Bush 套	2	A-02034	
32	Pump top 泵盖	1	A-02035	
33	Pressure plate 压板	1	A-02036	
34	Cap 盖	1	A-02037	
35	Cap 盖	1	A-02038	Model A, C
			AB-02038	Model B
36	Bush 套	2	A-02041	
37	Bush 套	1	A-02042	
38	Bush ..	1	A-02043	
39	Bush ..	1	A-2044A	
40*	Spindle 主轴	1	A-02051	Model A, C
			AB-02051	Model B
41	I shaft	1	A-02052	
42	II shaft	1	A-02053	
43	III shaft	1	A-02054	
44	IV shaft	1	A-02055	
45	V shaft	1	A-02056	Model A, C
			AB-02056	Model B
46	VI shaft	1	PM-02057	
47	IX shaft	1	A-02058	
48	X shaft	1	A-02059	
49	VIII shaft	1	A-02061	
50	XI shaft	1	A-02062	
51	XII shaft	1	A-02063	
52	XIII shaft	1	A-02064	
53	XIV shaft	1	A-02065	
54	Shaft 轴	1	A-02066	
55	Shaft ..	1	A-02067	
56	Shaft ..	1	A-02068	
57	Shaft ..	1	A-02069	
58	Shaft ..	1	A-02071	
59	Shaft ..	1	A-02072	
60	Shaft ..	1	A-02073	
61*	Shaft ..	1	A-02074	Swing over bed 400[16"]
			A-02074	Swing over bed 500[20"]
62	Shaft ..	1	A-02075	
63	Shaft ..	1	A-02076	
64	Shaft ..	1	A-02077	
65	Shaft ..	1	A-02078	
66	Gear 齿轮	1	A-02081	
67	Gear ..	1	A-02082	



Continuous table 2

68	Gear 齿轮	1	A-02083	
69	Gear	1	A-02084	
70	Gear	1	A-02085	
71	Gear	1	A-02086	
72	Gear	1	A-02087	
73	Gear	1	A-02088	
74	Gear	1	A-02089	
75	Gear	1	A-02091	
76	Gear	1	A-02092	
77	Gear	1	A-02093	
78	Gear	1	A-02094	
79	Gear	1	A-02095	
80	Gear	1	A-02096	
81	Gear	1	PM-02097	
82*	Gear	1	A-02098	Model A, C
			AB-02098	Model B
83	Gear	1	A-02099	
84	Gear	1	A-02101	Model A, C
			AB-02101	Model B
85	Gear	1	A-02102	Model A, C
			AB-02102	Model B
86	Gear	1	A-02103	
87	Gear	1	A-02104	Model A, C
			AB-02104	Model B
88	Gear	1	A-02105	
89	Gear	1	A-02106	
90	Gear	1	A-02107	
91	Gear	1	A-02108	
92	Gear	1	A-02109	
93	Gear	1	A-02111	
94	Gear	1	A-02112	
95	Gear	1	A-02113	
96	Gear	1	A-02114	
97	Chain gear 链轮	2	A-02121	
98	Tension wheel 张紧轮	1	A-02122	
99	Cam 凸轮	1	A-02123	
100	Brake wheel 制动轮	1	A-02124	
101	Ring 环	1	A-02131	
102	Bush 套	1	A-02132	
103	Shield ring 挡环	2	A-02133	
104	Shield ring	2	A-02134	



Continuous table 3

105	Shield ring 挡圈	2	A-02135	Model A, C
			AB-02135	Model B
106	Lever 杠杆	1	A-02136	
107	Bush 套	1	A-02137	
108	Bush	1	A-02138	Model A, C
			AB-02138	Model B
109	Bush	1	A-02139	
110	Bush	1	A-02141	
111	Bush	1	A-02142	
112	Bush	1	A-02143	
113	Bush	2	A-02144	
114	Screw cap 螺帽	1	A-02145	
115	Screw cap	1	A-02146	Model A, C
				Model B
116	Screw cap	2	A-02147	
117	Screw bolt 螺栓	1	A-02148	
118	Pulling plate 拉板	1	A-02149	
119	Pulling plate seating 拉板座	1	A-02151	
120	Key 键	1	A-02152	
121	Key 键	2	A-02153	
122	Sleeve 隔套	2	A-02154 A	Model A, C
			A-02154A	Model B
		1	AB-02154	
82	Gear	1	A-02098	
83	Gear	1	A-02099	
84	Gear	1	A-02101	
85	Gear	1	A-02102	
86	Gear	1	A-02103	
87	Gear	1	A-02104	
88	Gear	1	A-02105	
89	Gear	1	A-02106	
90	Gear	1	A-02107	
91	Gear	1	A-02108	
92	Gear	1	A-02109	
93	Gear	1	A-02111	
94	Gear	1	A-02112	
95	Gear	1	A-02113	
96	Gear	1	A-02114	
97	Chain gear 链轮	2	A-02121	
98	Tension wheel 张紧轮	1	A-02122	
99	Cam 凸轮	1	A-02123	



Continuous table 4

100	Brake wheel	制动轮	1	A—02124	
101	Ring	环	1	A—02131	
102	Bush	套	1	A—02132	
103	Shield ring	挡环	2	A—02133	
104	Shield ring	挡环	2	A—02134	
105	Shield ring	挡圈	2	A—02135	
106	Lever	杠杆	1	A—02136	
107	Bush	套	1	A—02137	
108	Bush	套	1	A—02138	
109	Bush	套	1	A—02139	
110	Bush	套	1	A—02141	
111	Bush	套	1	A—02142	
112	Bush	套	1	A—02143	
113	Bush	套	2	A—02144	
114	Screw cap	螺帽	1	A—02145	
115	Screw cap	螺帽	1	A—02146	
116	Screw cap	螺帽	2	A—02147	
117	Screw bolt	螺帽	1	A—02148	
118	Pulling plate	拉板	1	A—02149	
119	Pulling plate seating	拉板座	1	A—02151	
120	Key	键	1	A—02152	
121	Key	键	2	A—02153	
122	Sleeve	隔套	2	A—02154	
123	Pull rod	拉杆	1	A—02155	
124	Pull rod	拉杆	1	A—02156	
125	Link lever	连杆	1	A—02157	
126	Screw	螺帽	4	A—02158	
127	Block	块	1	A—02159	
128	Block	块	1	A—02161	
129	Block	块	1	A—02162	
130	Block	块	1	A—02163	
131	Block	块	1	A—02164	
132	Pillow	垫	4	A—02165	
133	Ring	环	1	PM-02508	
134	Pillow	垫	1	A—02167	
135	Pillow	垫	1	A—02168	
136	Pillow	垫	2	A—02169	
137	Handlebar	手把	1	A—02172	
138	handlebar	手把	1	A—021273	
139	handlebar	手把	3	A—02174	
140	Indicator	指示标	5	A—02175/1	



Continuous table 5

141	Pressure plate 压板	1	A—02176	
142	Strongback 定位板	1	A—02177	
143	Strongback	2	A—02178	
144	Balance weight 平衡块	Circa 6	A—02179	
145	Pin 销	5	A—02181	
146	Pin	2	A—02182	
147	Eccentric pin 偏心销	1	A—02183	
148	Screw bolt 螺栓	1	A—02184	
149	Pillow 垫	1	A—02185	
150	Sliding piece 滑块	1	A—02186	
151	Indicator 指示标	1	A—021475/1	
152	Oil pan 油盘	1	A—02191	
153	Friction disc 摩擦盘	16	A—02192	
154	Friction disc	14	A—02193	
155	Brake band 制动带	1	A—02194	
157	Oil pan 油盘	2	A—02196	
158	Drain line 放油管	1	A—02197	
160	Plate 标牌	1	A—02202	
161	Plate	1	A—02203	
162	Outer rotor 外转子	1	A—02211	
163	Inner rotor 内转子	2	A—02212	
164	Oil filter 滤油网	1	A—02221	
165	Friction disc 摩擦盘	1	A—02231	
166	Oil pipe 油管	1	A—02241	
167	Oil pipe	1	A—02242	
168	Oil pipe	1	A—02243	
169	Oil pipe	1	A—02244	
170	Oil pipe	1	A—02245	
171	Small hex head bolt 小六角头螺栓	1	M12x20 J21-1	
172		1	M16x60 J21-1	
173		2	M16x80 J21-1	
174		3	M20x60 J21-1	
175	Oblate hex nut 六角扁螺母	3	M8 J11-2	
176		2	M12 J11-2	
177		1	M12x1.25 J11-2	
178		2	M16x1.5 J11-2	
179		1	M20 J11-2	
180	Locking nut 压块紧锁螺母	1	M36x1.5 J14-6	
181		1	GM80x1.5 J14-6	



Continuous table 6

182		1	GM100x1.5 J14-6	
183	Cylinder head screw 圆柱头螺钉	10	M6x16 J21-8	
184	Half round screw 半圆头螺钉	4	M6x10 J21-4	
185	Sunk head screw 沉头螺钉	3	M5x12 J21-6	
186		4	M6x12 J21-6	
187	Socket head cap screw 内六角螺钉	3	M8x25 J21-9	
188		24	M10x25 J21-9	
189	Taper-end holding screw 锥形端固定螺钉	1	M10x40 J22-4	
190	Taper-end holding screw 锥形端固定螺钉	4	M8x20 J22-6	
191	Flat-end holding screw 平端固定螺钉	2	M12x14 J22-3	
193	End holding screw 尾端固定螺钉	2	M8x14 J22-5	
194	Socket head holding screw 内六角固定螺钉	6	M8x1x10 J22-9	
195	Square head screw 四方头螺钉	2	M10x25 J21-7	
196	Washer 垫圈	1	12 J51-1	
197		1	20 J51-1	
198	Slot washer 开口垫圈	1	A12-40 J51-5	
199	Single-ear stopping washer 单耳止退垫圈	1	6 J55-3	
200	Taper pin 圆锥销	1	6x30 J41-1	
210		2	6x45	
211	Inner screwed taper pin 内螺紋圆锥销	1	8x40 J41-2	
212	Straight pin 圆柱销	1	3x10 J44-1	
213		2	3x16 J44-1	
214		2	5x10 J44-1	
215		1	5x25 J44-1	
216		1	5x40 J44-1	
217		8	6x16 J44-1	
218		4	6x25 J44-1	
219		1	8x20 J44-1	
220		1	8x28 J44-1	
221		1	12x70 J44-1	
222	Sunk head rivet 沉头铆钉	3	3x8 J82-167	
223	Rivet for plate 板用铆钉	18	2x4 J83-1	
224	Shaft end check ring 轴端挡圈		B30 J64-1	
225	Circlip for hole 孔用弹性挡圈	2	47 J62-3	
226		1	80 J62-3	
227	Circlip for shaft 轴用弹性挡圈	1	16 J62-2	
228		1	18 J62-2	
229		1	22 J62-2	
230		2	25 J62-2	
231		2	30 J62-2	
232		2	35 J62-2	



Continuous table 7

233		1	40	J62-2	
234		1	58	J62-2	
235		1	75	J62-2	
236	Steel ball 钢球	4	10	GB308—64	
237		4	5x5x10	J31-1A	
238		2	6x6x16	J31-1A	
239		1	8x7x35	J31-1A	
240	Flat key 普通平键	1	12x8x50	J31-1A	
241		1	12x8x70	J31-1A	
242		3	16x10x50	J31-1A	
243		3	5x19	J33-1A	
244	Semicircular key 半圆键	2	6x19	J33-1A	
246	Seal nut 封口管螺母	1	G1/2"	G34-2	
247	Inner hex oil plug 六角油塞		M16x1.5	G38-4	
248	Rubber blanket 橡胶毯	1	I-1,10	66HG4-330-66	
249		1	12x1.9	G51-2	
250	"O"-ring O型密封圈	1	16x2.4	G51-2	
251		4	25x2.4	G51-2	
252		1	80x3.1	G51-2	
253		1	125x3.1	G51-2	
254	"O"-ring	1	135x3.1	G51-2	
255		1	180x5.7	G51-2	
256	Pipe junction 管接头	3	6	G91—1	
257		1	10	G91—1	
258		3	6	G91—2	
259	Closed joint insert 闭合型	1	10	G91—2	
260	Shaft sleeve 轴套	1	B-Cu 30x25	Q41-1	
261	Sleeve for shaft 内衬套	1	J-80x16	Q43—1	
262*		1	28x35x20	Q43-1-J	Swing over bed 400[16"]
			28x35x60	Q43-1-J	Swing over bed 500[20"]
263	Sleeve	1	30x37x20	Q43-1-J	
264		1	30x37x60	Q43-1-J	
265	隔套	2	40x48x25	Q43-1-J	
266		1	75x85x14	Q43-1-J	
267		1	40x48x20	Q43-1-J	
268		1	38x47x30	Q43-1-J	
269	Salver 顶盘	1	90	Q55-8	
270		1	80	Q55-8	



Continuous table 8

271	Plug 堵塞	4	6	Q56-1	
272		1	25	Q56-1	
273	Plug	1	50	Q56-1	
274	Fitting pin 定位销	1	170	Q71-1-34	
275	Pressure spring 压力弹	2	0.8x5x16	Q81-1	
276		3	1.6x8x18	Q81-1	
277		-1	1.6x10x25	Q81-1	
278		1	2x25x40	Q81-1	
279	Sliding piece 滑块	4	12	Q99-1	
280		7	B-12	Q99-1	
281		1	16	Q99-1	
282	Roundness oil leveler 油封	2	20	R51-2	
283	Holder 油封支持器	1	0.5x25	R95-1	
284	Bearing	5	25x47x12	105	
285		1	30x55x13	106	
286		2	25x52x15	205	
287		3	48x80x18	208	
288		2	25x62x17	305	
289		2	30x72x19	306	
290		2	35x80x21	307	
291		1	40x90x23	308	
292		1	75x130x25	D215	
293		Double-lined axipetal cylinder roller bearing 双列同心短圆柱 滚子轴承	1	80x125x34	D3182116
294	滚子轴承	1	100x150x37	1D3182120K	
295	Bilateral thrust angle- contact bearing 双向推力角接触轴承	1	100x150x60	5D2268120	
296	Single-lined taper roller bearing 单列圆锥滚子轴承	1	45x85x21	7209	
297		1	40x90x35.5	7608	
298	Single-row bush roller chain 单排套筒滚子链	1	Pitch 12.7(bicycle chain) overall length 46 sections		
300	Wiresteel ring 钢丝挡圈	1	70	J62-6	
301	Pillow 垫	1	PM-02509		
△	Stopping washer 止限 垫圈	1	AB-02041		Add in model B



Table 18-3 Tailstock

Serial No.	Name	Qty	Part No.	Remark
1*	Tailstock body. 尾座体	1	A-03001	Model A、B、C Swing over bed 400mm [16"]
			A ₁ -03001	Model A、B、C Swing over bed 400mm [16"]
2	Lower brake-rod-shoe 下闸块	1	A-03009	
3	Upper brake-rod-shoe 上闸块	1	A-03008	
4	Washer 垫圈	1	A-03042	
5	Screw bolt 螺栓	1	A-03032	
6	Pin 销	1	5x25 J44-1	
7	Handle 手柄	1	A-03033	
8	Screw 螺钉	1	M5x10 GB833-67	
9	Key 键	1	A-03035	
10	Oil cup 油杯	1	10 R71-1	
11*	Quill 套筒	1	A-03021	Metric lathe
			AB-03021	Inch lathe
			A-02021-A	Metric and Inch double-scale
12*	Nut 螺母	1	A-03005	Metric lathe
			A-03005-n	Inch lathe
13	Pin 销	1	5x25 J41-1	
14	Socket head cap screw 六角头螺栓	3	M6x20 J21-9	
15	Key 键	1	A-03036	
16	Elastic collar 弹性垫圈	1	10 J54-1	
17	Screw 螺栓	1	M10x16 J21-8	
18*	Leadscrew 丝杠	1	A-03022	Metric and Inch lathe
			A-03022-n	Lathe of the whole inch
19	Semicircular key 半圆键	1	22 J33-1A	
20	Thrust bearing 推力轴承	1	8205 GB301-84	
21	Bearing seat 轴承座	1	A-03004	
22	Oil cup 油杯	1	10 R71-1	
23	Socket head cap screw 六角头螺栓	4	M8x20 J21-9	
24	Handle 手柄	1	8-250x22 Z54-2	
25	Washer 垫圈	1	16 J51-1	
26	Nut 螺母	2	M16 J11-1	
27	Handle sleeve 手柄套	1	Z13-1-J-31	
28	Handle lever 手柄杆	1	Z13-1-J-32	
29	Wiresteel ring 钢丝圈	1	Z13-1-J-33	
30	Handle 手柄	1	A-03033	
31	Holding screw 紧螺栓	1	M8x16 J22-6	
32	Handle seating 手柄座	1	A-03006	



Continuous table 1

33	Pin	1	5x30 J41-1	
34	Pin	1	8x16 J41-1	
35	Bush 套	1	A-03011	
36	Screw	1	A-03037	
37	Semicircular key 半圆键	1	5x19 J33-1A	
38	Eccentric pin 偏心轴	1	A-03023	
39	Bush	1	A-03012	
40	Pressure plate 压板	1	A-03031	
41	Spherical washer 球面垫圈	1	20 J53-1	
42	Taper washer 锥面垫圈	1	20 J53-2	
43	Nut	1	M20x1.5 J11-2	
44	Pin	4	A-03044	
45	Annular ball bearing	4	17	
46	Bush 同心轴衬套	4	A-03043	
47	Rubber blanket 橡胶垫	4	A-03047	
48	Pillow 垫	4	A-03045	
49	Steel ball 钢球	4	10 GB308-64	
50	Pillow 垫	4	A-03046	
51	Pressure 压板	1	A-03003	
52	Screw	1	A-03039	
53	Pin	1	5x14 J41-1	
54	Chip scraper 刮屑板	2	A-03049-B	
55	Screw	1	A-03038	
56	Screw	8	M6x10 J21-4	
57	Chip scraper	2	A-03048-B	
58	Holding screw 紧束螺钉	4	M6x18 J22-3	
59	Bottom plate 底板	1	A-03002	
60	Washer	2	20 J51-1	
61	Nut	1	A-03041	
62	Nut	1	M20 J11-3	
63	Nut	1	A-03007	
64	Socket head cap screw	2	M12x120 J21-9	
65	Holding screw	2	M8x25 J22-6	
66	Socket head cap screw	2	M12x28 J21-9	
67	Plate 标牌	1	PQ-03088	
68	Plate ..	1	PQ-030889	



Table 18-4 Saddle and carriage

Serial No.	Name	Qty	Part No.	Remark
1*	Saddle 鞍	1	A-05001-A	
			A-05001-R	Right-handwheel
2	Hind pressure plate 后压板	1	A-05042A	
3	Screw	8	M8x16 J21-6	
4	Chip scraper	1	A-05064-A	
5	Chip scraper	1	A-05063-A	
6*	Felt gasket 毛毡垫	2	A-05083	Subassembly of oil cup in model A、C
7*	Oil cup	2	A-05058	
8*	Oil cup cap 油杯盖	2	A-05067	
△	Oil cup cap 油杯盖	(2)	AB-05411	Subassembly of oil cup in model B
△	Oil cup cover 油杯罩	(2)	AB-05412	
△	Rotating cover 转盖	(2)	AB-05413	
△	Felt gasket 毛毡垫	(2)	AB-05083	
9	Block 块	2	A-05091A	
10*	Nut	1	A-05011	Metric lathe
			AB-05011	Inch lathe
11	Clout 垫片	1 group	A-05069	Quantity and thickness confirmed by assembling
12	Board 板	2	A-05044A	
13	Hind pressure plate 后压板	1	A-05041A	
14	Front pressure plate 前压板	2	A-05006	
15	Nut	4	M10 J11-1	
16	Screw	4	M10x40 J21-1	
17	Screw	4	M10x30 J22-2	
18	Clip scraper 刮屑板	1	A-05061-A	
19	Clip scraper	1	A-05062-A	
20	Pressure plate	1	A-05043	
21	Pin	1	8x25 J44-1	
22	Socket head screw	4	M12x50 J21-9	
23	Socket head screw	4	M12x60 J21-9	
24	Pin	2	8x60 J41-2	
25	Oil cup	5	10 R71-1	
26	Screw	1	M12x70 J21-7	
27*	Leadscrew 丝杆	1	A-05021	Metric lathe
			AB-05021	Inch lathe
28	Semicircular key	3	5x19 J33-1A	
29	Bush 套	1	A-05007	
30	Gear	1	A-05031	
31*	Supporting 支承座	1	A-05003	Metric lathe
			AB-05003	Inch lathe



Continuous table 1

32	Screw	4	M8x20 J21-1	
33*	Scale ring 刻度环	1	100x18x100-n Q67-4-J-32	Used in metric lathe
			AB-05041	Used in Inch lathe
34	Elastic slice 弹性片	1	80~125 Q67-4-J-33	
35	Inner ring 内环	1	A-05004A	
36	Steel ball 钢球	1	8 GB308-64	
37	Pin	1	A-05049	
38	Pin	1	3x12 J44-1	
39	Handle bar 把手	1	A-05051	
40	Nut	2	M18x1.5 J14-4	
41	Pin	1	5x30 J41-1	
42	Handle	1	(Cr)L14x65 Z42-1	
43	Handle	1	(Cr)L10x80x22 Z11-1	
44	Cross slide 下刀架	1	A-05002	
45	Socket head cap screw	2	M10x25 J21-9	
46	Bush	1	A-05046	
47	Socket head cap screw	2	M10x55 J21-9	
48	Cap	1	A-05071	
49	Screw	1	M6x10 J21-4	
50	Screw	2	M10x30 J22-11	
51	Pillow 垫	2 (6)	A-05066	Altogether 6 pieces, 4 pieces used in other unit
52	Spring 弹簧	2	1.6x10x25 Q81-1	
53	Screw	2	M6x30 J21-8	
54	Guard shield	1	A-05065	
55	Holding screw 护罩	1	M8x25 J22-5	
56	Pin	1	6x25 J44-1	
57	Washer 垫圈	1	A-05048	
58	Gib 垫条	1	A-05005	
59	Top slide 中刀架	1	A-04001	
60	上刀架	1	A-05002	
61	Nut	1	A-04011	
62	Leadscrew	1	A-04031	
63	Pin	1	5x30 J41-1	
64	Eccentric sleeve 偏心套	1	A-04004	
65	Scale ring 刻度环	1	60x18x100-n Q67-4-J-32	
66	Elastic slice 弹性片	1	50~60 Q67-4-J-31	
67	Inner ring	1	6x18 Q67-4-J-31	
68	Handle	1	A-04021	
69	Handle	2	(Cr)L6x50x16 Z11-1	
70	Tool post 刀架	1	A-04041	



Continuous table 2

71	Pin	1	A-04044	
72	Spring	2	1.6x8x75 Q81-1	
73	Holding screw	1	A-04052	
74	Capping 压盖	1	A-04045	
75	Screw	2	M8x16 J21-8	
76	Washer	1	A-04056	
77	Check ring 挡圈	1	A-04048	
78	Handle seating	1	A-04046	
79	Handle	1	A-04047	
80	Screw	1	A-02049	
81	Pin	1	5x25 J44-1	
82	Screw	1	A-04055	
83	Spring	1	1x6x25 Q81-1	
84	Steel ball 钢球	1	6 GB308-64	
85	Spring	1	A-04062	
86	Zygote 接合子	1	A-04061	
87	Cam	1	A-04043	
88	Shaft	1	A-04042	
89	Holding screw	1	M16x40 J22-1	
90	Holding screw	1	M12x14 J22-3	
91	Spring	1	(Y) 1x8x25 Q81-1	
92	Pin	1	A-04054	
93	Bush	4	A-04059	
94	Pillow	1	A-04058	
95	Gib	1	A-04003	
96	Screw	1	A-04053	
97	Steel ball	1	3/4" GB308-65	
98	Oil cup	2	6 R71-1	
99	Holding screw	1	M12x25 J22-3	
100	Holding screw	2	M6x8 J22-3	
101	Nut	2	M12 J11-1	
102	Pillow	2	12 J51-1	
103	Screw	2	A-04051	
104	Holding screw	1	M10x35 J22-5	



Table 18-5 Apron

Serial No.	Name	Qty	Part No.	Remark
1*	Apron 溜板箱	1	A-06001-A	Model A
			AB-06001	Model B
			AC-06001	Model C , 2500~5000mm
			A-06001-R	Right-handwheel,750~2000mm
			PM-06101/F	Right-handwheel,2500~5000mm
2	Handle sleeve 手柄套	1	85 Z13-1-J-31	
3	Wiresteel ring 钢丝圈	1	1.2x13 Z13-1-J-33	
4	Handle lever 手柄杆	1	85x20 Z13-1-J-32	
5	Handwheel 手轮	1	A-06005	
6*	Supporting	1	A-06002	Model A
			AB-06002	Model B
7	Screw	3	M8x55 J21-9	
8	Pin	2	8x60 J41-2	
9	Pin	1	12x40 J44-1	
10	Shaft sleeve	1	18x25 Q41-1	
11*	Gear	1	A-06073	Metric
			AB-06073	Inch
12*	Gear	1	A-06074A	Metric
			AB-06074A	Inch
13	Handle bar 把手	1	A-05051	
14	Pin	1	A-05049	
15	Pin	1	5x19 J33-1	
16	Steel ball	1	6 GB308-64	
17	Elastic slice 弹性片	1	80~125 Q67-4-J-33	
18*	Index ring 分度环	1	A-06088	Metric
			AB-06088	Inch
19,180	Pin	1	6x25 J44-1	
20*	Seat ring 座圈	1	A-06006	Metric
			AB-06006	Inch
			A-06006-R	Right-handwheel
21	Seal ring 密封圈	1	18x2.4 HG4-333	
22	Bush	1	A-06011	
23,178	Pillow	2	A-06115	
24	Gear	1	A-06071	
25	Shaft sleeve	1	20x16 Q41-1	



Continuous table 1

26	Pillow	1	A-06114	
27	Clutch 离合器	1	A-06112	
28	Spring	1	1.6x18x25 Q81-1	
29	Washer	1	14 J51-1	
30,52	Semicircular key	3	5x19 J33-1	
31	I shaft	1	A-06051	
32	Flat key 平键	1	4x4x20 J31-1	
33	Split pin 开口销	1	4x25 J44-9	
34	Circular oil leveler 油位器	1	20 R51-2	
35	II shaft	1	A-06052	
36,63	Semicircular key	2	8x32 J33-1	
37	Seal ring	1	32x3.5 HG4-333	
38	Gear	1	A-06069	
39	Seal ring	1	25x2.4 HG4-333	
40	Oiliness bushing 油封	1	A-06031	
41	Pin	1	5x35 J41-1	
42*	Gear	1	A-06072	Metric
			AB-06072	Inch
43, 126*	Cap	2	A-06121	750~2000mm
			AC-06121	2500~5000mm
44,125	Screw	8	M8x16 J21-6	
45,66	Seal ring	3	35x3.1 HG4-333	
46,65	Oiliness bushing	3	A-06032	
47,54	Gear	4	A-06066	
48,55,96, 140,145	Holding screw	7	M6x10 J22-4	
49,53	Bush	4	A-06025	
50	Zygote 轴套	2	A-06089	
51	III(VI)shaft	2	A-06053	
56	Gear	2	A-06065	
57,58	Oiliness bushing	3	A-06033	
59	Gear	1	A-06064	



Continuous table 2

60*	Wormwheel	1	A-06021	
			A-06021-R	Right-handwheel
61	定位螺钉 Locating screw	1	M8x16 J22-6	
62	Semicircular key	1	6x22 J33-1	
64	V shaft	1	A-06055	
67	Stopples 堵塞	1	25 Q56-1	
68*	VII shaft	1	A-06056	750~2000mm
			A-06056-R	Right-handwheel, 750~2000mm
			AC-06056	2500~5000mm
			AC-06056-R	Right-handwheel, 2500~5000mm
69	Shaft sleeve	1	32x25 Q41-1	
70*	Handle seating	1	A-06099	
			A-06099-R	Right-handwheel
71	Pin	1	5x60 J41-1	
72	Handle	1	A-06102	
73	Pin	1	4x30 J41-1	
74	Screw	1	A-06095	
75	Steel ball	1	8 GB308-64	
76,198	Spring	4	1.6x8x22 Q81-1	
77	Screwed bush 螺套	1	A-06127	
78,112	Screw	2	M10x25 J22-3	
79	Handle	1	A-06101	
80,162	Check ring 挡圈	2	30 J62-2	
81	Sleeve 隔套	1	30x37x4 Q43-1-J	
82*	Handle seating	1	A-06098	
			A-06098-R	Right-handwheel
83,193	Pin	2	5x30 J41-1	
84	Splicing sleeve 接套	1	A-06107	Diameter of motor shaft Φ 14
		1	A-06107A	Diameter of motor shaft Φ 11
85	Pillow	1	A-06141	
86	Quick speed motor	1		
87	Flat key	1	4x4x12 J31-1	Motor belt
88	Bolt 螺钉	3	M8x25 J21-1	
89	Button seating 按钮	1	A-06105	
90	Handle header 手柄头	1	A-06104	
91	Nut	1	M12x1.25 J11-2	



Continuous table 3

92	Cap	1	A-06151	
93	Cap	1	A-06012	
94	Handle	1	A-06103	
95	Pin	1	8x25 J44-1	
97	Guard shield 护罩	1	A-06003	
98,171	Screw	8	M8x20 J21-9	
99	Bracket 支架	1	A-06043	
100	Shaft sleeve	1	B35x35 Q41-1	
101,123	Screw	2	M8x10 J22-4	
102	Screw	1	M6x16 J22-4	Used in lathe 1.5M,2M
103*	Bush	1	A-06026	Used in lathe 1.5M,2M
			AC-06026	2500~5000mm
104	Pin	2	12x25 J44-1	
105*	Split-nut 对合螺母	1	A-06022	Metric ,750~2000mm
			AB-06022	Inch ,750~2000mm
			AC-06022	Metric ,2500~5000mm
			AC-06022-n	Inch ,2500~5000mm
106,113	Screw 螺母	3	M10 J11-1	
107	Screw	2	A-06094	
108	Gib	1	A-06111	
109,128	Screw	8	M6x10 J21-6	
110*	Split-nut seating 对合螺母座	1	A-06004	750~2000mm
			A-06004-R	Right-hand wheel, 750~2000mm
			AC-06004	2500~5000mm
			PM-06004/B	Right-handwheel,2500~5000mm
111	Pin	1	8x50 J44-1	
114	Screw	1	M10x25 J21-9	
115	Check ring	1	20 J62-2	
116	Washer	1	20 GB848-66	
117	Shaft sleeve	1	28gax20 Q41-1	
118,120,124	Holding screw	3	M6x8 J22-3	
119*	Gear	1	A-06067	
			A-06067-R	Right-handwheel
121*	Gear	1	A-06068	
			A-06068-R	Right-handwheel



Continuous table 4

122	IVshaft	1	A-06054	
127	Paper pillow 纸垫	1	A-06132	
129	Cap	1	A-06122	
130	Paper pillow	1	A-06133	
131	Check ring	1	18 J62-2	
132,135	Pillow	2	A-06109	
133	Gear	1	A-06062	
134	Shaft sleeve	1	25x25 Q41-1	
136	IXshaft	1	A-06058	
137	Check ring	1	38 J62-2	
138	Sleeve 隔套	1	38x47x4 Q43-1-J	
139	Bush 套	1	A-06024	
141	Gear	1	A-06061	
142	Flat key	1	6x6x25 J31-1	
143	Feed rod sleeve 光杆套	1	A-06082	
144	Bush	1	A-06023	
146,172	Bearing	2	25x52x16.5 7205	
147*	VIIshaft	1	A-06057	
			A-06057-R	Right-handwheel
148,197	Screw	4	M6x10 J21-4	
149	Flat key	1	8x7x30 J31-1	
150	Oil strap 油杯	1	A-06123	
151	Pillow	1	A-06108	
152	Gear	1	A-06063	
153	Spring	3	0.3x3x12 Q81-1	
154	Pin	3	4 C31-1-35	
155	Roller 滚子	3	8 C31-1-34	
156*	Clutch body 离合 器体	1	A-06083A	
			A-06083-R	Right-handwheel
157	Flat key	1	8x7x16 J31-1	
158	Zygote 结合子	1	A-06084	
159	Zygote	1	A-06085	
160	Steel ball	4	10 GB308-64	
161	Spring	4	1.6x8x32 Q81-1	



Continuous table 5

163	Pillow	1	A-06086	
164	Wire 铁丝		Φ0.8	
165	Screwed stopple 丝堵	4	A-06096	
166	Sliding board 滑板	1	A-06087	
167	Holding screw	1	M12x60 J22-9	
168	Nut	1	M12 J11-2	
169	Seal ring	1	95x3.1 HG4-333	
170	Bearing seat	1	A-06007	
173	Screwed loop	1	A-06097	
174,205	Screw	2	M5x12 J21-6	
175	Seal ring	1	56x3.5 HG4-333	
176	Cover 帽	1	A-06125	
177	Check ring	1	14 J62-2	
179	Lever 杠杆	1	A-06013	
181,191	Sliding piece 滑块	5	12 Q99-1	
182	Shaft	1	A-06113	
183	Cap	1	A-06161	
184	Check ring	1	22 J62-4	
185	Oil plug 油塞	1	A-06116A	
186	Seal ring	1	16x2.4 HG4-333	
187	Shaft	1	A-06091	
188	Transmission fork 拨叉	1	A-06041	
189*	Transmission fork	1	A-06042 A-06042-R	Right-handwheel
190	Pin	4	6x14 J44-1	
192	Interlock pin seating 互锁销座	1	A-06009	
194	Interlock pin 互锁销	1	A-06092	
195	Stopples 堵塞	1	35 Q56-1	
196*	Controlling shaft 操纵轴	1	A-06081 A-06081-R	Right-handwheel
199	Pin	3	A-06106	
200	Paper pillow	1	A-06131	
201	Cap	1	A-06008	
202	Screw	6	M8x16 J21-1	



Table 18-6 fced box 进给箱

Serial No.	Name	Qty	Part No.	Remark
1	Box 箱体	1	A-07001	
2	Cover 盖	1	A-07133	
3	Cap	1	A-07132A	
4*	Plate 标牌	1	A-07151	Used in metric lathe
			AB-07151	Used in Inch lathe
5	Bush	1	A-07012	
6	Top 箱盖	1	A-07002A	
7	Socket head cap screw	2	M12x50 J21-9	
8	Pin	2	10x60 J41-2	
9	Screw	9	M8x12 J21-4	
10	Rivet for plate 标牌铆钉	24	2x4 J83-1	
11	Screw	4	M6x16 J21-8	
12	Spring	4	1x10x10 Q81-1	
13	Pillow	4	A-05056	
14	Screw bolt 螺杆	2	A-07126A	
15	Socket head cap screw	6	M10x30 J2109	
16	Indicator 指示标	3	A-02175	
17	Pin	2	8x50 J41-2	
18	Paper pillow	1	A-07156	
19	Paper pillow	1	A-07155	
20	Cover 盖	1	A-07131	
21	Oil plug 油塞	1	M12x1.25 G38-2A	
22	Circular oil lever	1	20 R51-2	
23	Screw	3	M10x30 J21-11	
24	Shield ring for shaft 轴衬	1	17 J62-2	
25	Bearing 轴承	9	203 GB276-86	
26*	Gear	2	A-07066	
27	Shaft	1	A-07039	
28	Bearing	5	105 GB276-86	
29	Shield ring for shaft	3	25 J62-2	
30	Gear	1	A-07064	
31	Bearing	1	304 GB276-86	
32	Cap	1	A-07099	
33	Oil plug 油塞	2	M16x1.5 G38-4A	
34	Adjuster 调整圈	2	A-07122	
35	Gear	1	A-07067	
36	Gear	1	A-07068	
37	Gear	1	A-07069	
38	Shaft	1	A-07036	



Continous table 1

39	Bush 套	2	A-07119	
40	Wire 铁丝	2	Φ0.8x150	
41	Holding screw	2	M8x10 J22-5	
42	Gear	1	A-07071	
43	Gear	1	A-07072	
44	Gear	1	A-07073	
45	Cage ring 隔圈	2	A-07127	
46	Washer	5	A-07124	
47	Bush	1	25x32x28 Q43-1-J	
48	Gear	1	A-07063	
49	Shaft	1	A-07035	
50	Gear	1	A-07062	
51	Bearing	1	303 GB276-86	
52	Cap	1	A-07098	
53	Gear shaft	1	A-07032	
54	Semicircular key	1	4x19 J33-1A	
55	Cage ring	1	A-07128	
56	Bearing	1	205 GB276-86	
57	Gear	1	A-07065	
58	Gear	1	A-07061	
59	Bearing	1	305 GB276-86	
60	Shaft	1	A-07031	
61	Gear	1	A-07079	
62	Gear	1	A-07061	
63	Spring washer	2	35 J51-1	
64	Slot washer	1	A12-40 J51-5	
65	Gear	1	A-07074	
66	Shaft	1	A-07033	
67	Gear	1	A-07075	
68	Gear shaft	1	A-07034	
69	Bearing	2	7000106 GB276-86	
70	Washer	2	A-07123	
71	Thrust ball bearing	2	D8106 GB301-86	
72	Bearing seat	1	A-07004	
73	Socket head cap screw	8	M10x25 J21-9	
74	Cap	1	A-07125	
75	Bush	1	A-07015	
76	Nut	2	A-07121	
77	Bush	1	A-07095	
78	Pin	4	6x10 J41-1	
79	Gear	1	A-07076	



Continuous table 2

80	Gear	1	A-07077	
81	Shaft	1	A-07037	
82	Bush	1	A-07014	
83	Gear	1	A-07078	
84	Gear	1	A-07079	
85	Gear shaft	1	A-07038	
86	Bush	1	A-07096	
87	Cap	1	A-07003	
88	Washer	1	G51-1 25	
89	Bush	1	A-07096	
90	Shaft	2	A-07044	
91	Lever	1	A-07009	
92	Pin	5	J44-1 5n6×14	
93	Sliding piece	6	Q99-1 B-10	
94	Sliding piece	7	Q99-1 12	
95	Shaft	2	A-07111	
96	Cam	1	A-07093	
97	Drawable shaft	1	A-07114	
98	Lever	1	A-07011	
99	Shaft	1	A-07047	
100	“●” felt ring	2	G51-2A 25×2.5	
101	Key	6	J33-1A 5×19	
102	Shaft	1	A-07043	
103	Locating washer	2	Z34-2 22	
104	Screw	6	J21-6 M6×12	
105	Handle bar	2	A-02174	
106	Handwheel	2	A-02011	
107	Check ring	3	J64-1 B30	
108	Screw	3	J21-6 M5×12	
109	Steel ball	3	GB308-64 10	
110	Spring	2	Q81-1 YI-1.6×8×18	
111	Screw	2	J22-3 M12×14	
112	Pin	2	J44-1 6n6×14	
113	Shaft	2	A-07113	
114	Lever	1	A-07005	
115	Shaft	2	A-07046	
116	Lever	1	A-07006	
117	Circlip for shaft	1	J62-2 16	
118	Cam	2	A-07092	
119	Steel ball	6	GB308-64 5	
120	Sliding board	2	A-07094	



Continuous table 1

7	支架 Bearing bracket 托座	1	A-01005	Range from 750mm[30"]~ 2000mm[80"]
			AC-01005	Range from 2500mm[100"]~ 5000mm[200"]
8*	leadscrew 丝杆 大丝杆 导杆 螺母	1	A-01021/750	Metric 750mm[30"]
			A-01021/750-R	Metric 750mm[30"] right-handwheel
			A-01021/1000	Model A、metric model B 1000mm[40"]
			A-01021/1000-R	Metric 100mm[40"] right-handwheel
			A-01021/1500	Metric 1500mm[60"]
			A-01021/1500-R	Metric 1500mm[60"] right-handwheel
			A-01021/2000	Metric 2000mm[80"]
			A-01021/2000-R	Metric 2000mm[80"] right-handwheel
		1	AB-01021/750	Inch 750mm[30"]
			AB-01021/750R	Inch 750mm[30"] right-handwheel
			AB-01021/1000	Inch 1000mm[40"]
			AB-01021/100R	Inch 1000mm[40"] right-handwheel
			AB-01021/1500	Inch 1500mm[60"]
			AB-01021/1500R	Inch 1500mm[60"] right-handwheel
			AB-01021/2000	Inch 2000mm[80"]
			AB-01021/2000R	Inch 2000mm[80"] right-handwheel
		1	AC-01021/2.5m	Model C2500mm [100"]
			AC-01021/2.5mR	Model C 2500mm [100"] right-handwheel
			AC-01021/3000	Model C3000mm [120"]
			AC-01021/3M B	Model C 3000mm [120"] right-handwheel
			AC-01021/4000	Model C 4000mm [160"]
AC-01021/3M B	Model C 4000mm [160"] right-handwheel			
AC-01021/5000	Model C 5000mm [200"]			
9*	Feed rod 光杆	1	A-01022/750	Model A 、 B 750mm[30"]
			A-01022/1000	Model A 、 B 1000mm[40"]



Table 18-7 Transposing gear

Serial No.	Name	Qty	Part No.	Remark
1*	Transposing gear	1	A-08001	Model A 、 C metric lathe Swing over bed 400mm [16"]
			A1-08001	Model A 、 C metric lathe Swing over bed 500mm [20"]
			AB-08001	Used in Inch lathe
2	Screw	2	M6x10 J21-4	
3	Oil baffle	1	A-08031	Used in metric lathe
			AB-08031	Used in Inch lathe
4*	Gear	1	A-08042	Model A 、 C metric lathe Swing over bed 400mm [16"], Model B metric lathe swing over bed 400mm[16"]、 500mm[20"]
			A1-08042	Model A 、 C metric lathe 500[20"]
			AB-08044	Used in Inch lathe
5	Cap	1	A-08025	
6				
7	Shaft	1	A-08021	Used in metric lathe
			AB-08021	Used in Inch lathe
8				
9*	Gear	1	A-08043	Model A 、 C metric lathe Swing over bed 400mm [16"], Model B metric lathe Swing over bed 400mm[16"]
			A1-08043	Model A 、 C metric lathe swing over bed 500mm[20"]
			A1B-08046-t	Model B metric lathe swing over bed 500mm [20"]
			AB-08045	Used in Inch lathe
10	Spline housing	1	A-08011	
11	Pillow	1	A-08024	
12	Pin	1	8x6 J44-1	
13	Nut	1	A-08023	
14*	Gear	1	A-08044	Model A 、 C metric lathe Swing over bed 400mm [16"], Model B metric lathe .Swing over bed 400[16"]、 500[20"]
			A1-08044	Model A 、 C metric lathe swing over bed 500[20"]
			AB-08042	Used in Inch lathe



CL-100 (L172) PARTS LIST

Continuous table 1

15*	Gear	1	A-08041	Model A 、 C metric lathe Swing over bed 400[16"], Model B metric lathe Swing over bed 400mm[16"]、 500mm[20"]
			A1-08041	Model A 、 C metric lathe swing over bed 500mm[20"]
			AB-08043	Used in Inch lathe
△	Gear	1	A-08043	Model B metric lathe swing over bed 500mm[20"] Used in special thread turning
△	Gear	1	AB-08041	British lathe Used in special thread turning

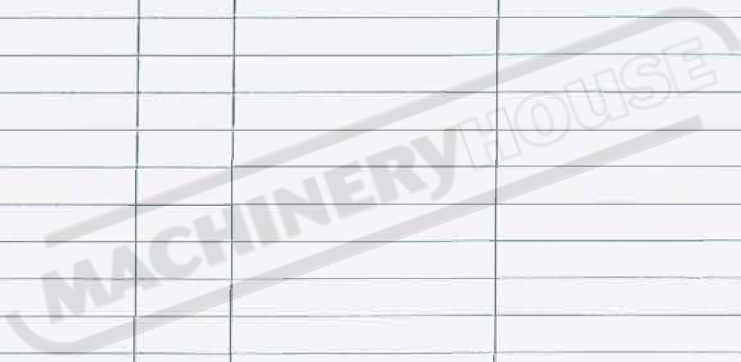



Table 18-8 Steady rest

Serial No.	Name	Qty	Part No.	Remark
1*	Handle	3	A-10105	
2	Pin	3	4x30 J41-1	
3	Screw bolt	3	A-10113	
4	Screwed bush	3	A-10115	
5	Sliding bush	3	A-10114	
6*	Holding screw	3	M10x12 J22-6	
7*	Steady rest upside	1	A-10101	
8*	Pin	3	6x45 J44-1	
9	Screw	3	A-10112	
10*	Pin	1	16x55 J44-1	
11	Resist head	3	A-10104	
12	Nut	1	M20 J11-3	
13	Pillow	1	20 J51-1	
14	Steady rest downside	1	A-10101	Model A、B swing over bed 400mm[16"]
			A1-10101	Model A、B swing over bed 500[20"]
15	Pressure plate	1	A-10103	
16	Screw	1	A-10111	
17	Pin	1	10x55 J44-1	
18	Screw	1	M12x60 J23-3	
19	Handle	1		



19 Easy worn parts

The easy worn parts of the machine are listed in table19-1. The other worn parts not listed in the table are universal parts of all type machine referred in this 《Operating Instruction》.

Table 19-1 Easy worn parts

Serial No.	Part No.	Part name	Material	Heat treatment	Qty	Remark
1	A02041	Bushing	ZQSn6-6-3		2	
2	A02136	Lever	45	Local G48	1	
3	A02192	Clutch disc	15	S0.5~ C0.6	16	
4	A02193	Clutch disc	15	S0.5~ C0.6	14	
5	A02194	Brake band	65Mn		1	
6	A02211	Outer rotor of trochoid pump	Sintered powder iron basic metal		1	
7	A02212	Inner rotor of trochoid pump	Sintered powder iron basic metal		1	
8	A02231	Brake friction disc	Canvas with iron sand		1	
9	A05011	Slide nut	ZQSn6-6-3		1	Model A,B Inch lathe
	AB05011					Model B Inch lathe
10	A06021	Worm wheel	ZQSn6-6-3		1	
11	A06022	Split-nut	ZQSn6-6-3		1	Model A,B Metric lathe
	AC06022					Model C
	AB05022					Model B Inch lathe
12	A08011	Spline bushing	ZQSn6-6-3		1	
13	J22-1	Screw M16x40	35		8	
14	Q99-1 12	Slide block	HT300		1	
15	Q99-1 16	Slide block	HT300		11	
16	S77-1 M5	Center MT5	T8	Tip C59 Shank C40	2	